

DTMRX2

OPERATING INSTRUCTIONS

CONTENTS

1 INTRODUCTION	2
1.1 Contents of the package	2
1.2 The contents of this manual	2
1.3 Typographical conventions	2
2 SAFETY RULES	3
3 IDENTIFICATION DATA	3
4 DESCRIPTION OF THE DTMRX2 (DTMRX224) RECEIVER	4
4.1 Features	4
4.2 Appliances compatible for use with the receiver	4
4.3 Examples of installation	5
4.4 Cables	6
5 INSTALLATION	7
5.1 Opening the package	7
5.2 Checking the markings	7
5.3 Configuration DIP switches and Jumpers	8
6 CONNECTING THE POWER SUPPLY	10
7 CONFIGURING THE RECEIVER	10
7.1 Setting the receiver identification number	11
7.2 Setting the communication rate	11
7.3 Setting the receiver protocol	12
7.4 Setting the auxiliary as Wiper	12
7.5 Setting receiver reception mode (RS232/RS485/COAX)	12
7.6 Inserting the load on the RS485 line	12
7.7 Connecting the control unit	13
7.8 Connection with the RS485 line	13
7.8.1 Connecting more than one receiver in cascade (point-to-point connection)	14
7.8.2 More than one receiver per line, connection with twisted pair (multi-point connection)	14
7.8.3 Mixed configurations (point-to-point /multi-point)	15
7.9 Connection with the RS232 line	15
7.10 Connection for reception by coaxial cable (COAX)	16
7.11 Type of controlled lenses and adjusting the lens control voltage	16
7.12 Connecting the pan & tilt and lens cables	16
8 SWITCHING ON AND OFF	17
9 MAINTENANCE	18
10 TROUBLESHOOTING	18
11 TECHNICAL SPECIFICATIONS	19

The manufacturer declines all responsibility for any damage caused by improper use of the appliances mentioned in this manual; furthermore, the manufacturer reserves the right to change the contents without prior notice. All due caution has been taken in gathering and checking the documentation contained in this manual; the manufacturer, however, cannot assume any liability arising from its use. This statement also holds for any person or company concerned with the creation and production of this manual.

1 Introduction

1.1 Contents of the package

- 1 DTMRX2 (DTMRX224) receiver
- 1 user's manual
- 2 PG11 closure plugs
- 4 wall fastening brackets with corresponding screws

When the product is delivered make sure the package is intact and has no obvious signs of dropping, scrapes or scratches. If the package is obviously damaged contact the supplier immediately.

Make sure the contents correspond to the list of materials as above.

1.2 The contents of this manual

This manual describes the DTMRX2 (DTMRX224) receiver, with its specific procedures for installation, configuration and use. **Read this manual carefully**, especially the section regarding safety rules, **before installing and using the receiver**.

1.3 Typographical conventions

This manual makes use of different graphics symbols, the meaning of which is summarised as follows:



Hazard of electric shock; disconnect the power supply before proceeding with any operation, unless specified otherwise.



This operation is very important for correct operation of the system: please read the procedure described carefully, and carry it out as instructed.



Description of system specifications: we strongly advise reading this part carefully so as to understand the stages that follow.

2 Safety rules



The DTMRX2 (DTMRX224) receiver complies with current legislation and standards regarding electrical safety, electromagnetic compatibility and general requirements in force at the time of this manual's publication. Nevertheless, in order to ensure the users' safety (installer technician and operator) the following warnings are specified in order to work in maximum safety:

- The appliance (and the whole system of which it forms part) must only be installed by authorised, skilled technical personnel.
- The appliance must only be opened by authorised, skilled personnel. Tampering with the appliance will invalidate the terms of the guarantee
- Connect the system to a power supply that corresponds to the indications on the identification labels (see the next section *Identification data*)
- The receiver should be connected to the power supply network using a multipolar switch with a minimum open contact distance of 3mm for each pole.
- The power supply outlet should be connected to earth in accordance with the legislation in force
- Before moving or carrying out technical work on the appliance, disconnect the power supply to the receiver
- The appliance is to be considered OFF only when the power supply is disconnected and the connection cables to other devices have been removed
- Use cables with an appropriate cross section (see the section on cables)
- Do not use power cables with signs of wear or ageing, since they could expose the user to serious safety hazards
- Install the cables so they do not get in the way of the operator
- Do not use the appliance in the presence of inflammable substances
- Do not allow children or incompetent persons to use the appliance
- Make sure the appliance is fixed firmly and safely
- For technical services refer only and exclusively to authorised technical personnel
- Keep this manual carefully for future consultation

3 Identification data



There is a label on the receiver containing:

- Product identification code
- Product serial number
- Power supply voltage (Volts)
- Frequency (Hertz)
- Consumption (Watts)
- IP protection rating

There is a label on the package containing:

- Product identification code (Extended 3/9 Bar-code)
- Product serial number (Extended 3/9 Bar-code)
- Short description of the product
- Power supply voltage (Volts)
- Frequency (Hertz)
- Consumption (Watts)
- IP protection rating

Before installing, make sure that the receiver's power supply specifications correspond to the specifications required. The use of inappropriate equipment may subject personnel and the system itself to serious safety hazards.

4 Description of the DTMRX2 (DTMRX224) receiver



The DTMRX2 (DTMRX224) receiver is microprocessor-controlled receiver for remote control of pan & tilt and motorised lenses.

4.1 Features

- 12 Functions: UP, DOWN, LEFT, RIGHT, AUTO, ZOOM TELE, ZOOM WIDE, FOCUS NEAR, FOCUS FAR, IRIS OPEN, IRIS CLOSE, AUX
- AUX: clean auxiliary contact 1A 230 V~ / 1A 24 V~
- 99 addresses selected by DIP switch
- Choice of communication between RS232, RS485 and Coaxial
- RS232, RS485 repeater for cascade configuration
- Choice of communication rate (1200, 9600, 19200, 38400 Baud)
- Choice of communication protocols: MACRO, Videotec standard, Pelco D (2400 Baud) and Coaxial
- Possibility of using both lenses operating in reverse polarity and lenses operating on common wire
- Auxiliary contact AUX can be set for Wiper operation
- EEPROM for storage of activated options
- Power supply LED
- Control reception LED
- Active function LED

For strictly technical specifications (consumption, power supply voltage etc.) see the section on Technical specifications.

4.2 Appliances compatible for use with the receiver

- **DCS3, DCTEL, DCJ, DCT, DCIR**: control keyboards.
- **SM42A, SM82A, SM84A, SM164A**: video matrixes with coaxial telemetry data transmission
- **DCRE485**: communications controller used for star control of more than one receiver using a single keyboard
- **PTH310, PTH910, NXPTH210** pan & tilt for **DTMRX2** version receiver
- **PTH311, PTH911, NXPTH211** pan & tilt for **DTMRX224** version receiver

NOTE: Using the **DCFIT** interface module, it is possible to control the receiver via the **DCS2** and **DCMT8** model receivers.

See the individual instruction manuals for complete descriptions of the appliance specifications.

4.3 Examples of installation



One operator, with more than one monitor, controls a series of pan & tilt with receivers configured in cascade using a RS485 telemetry line:

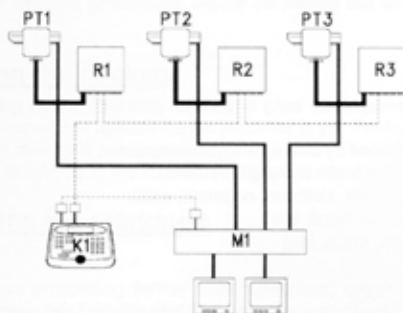

MATERIALS

Control part:
K1: DCJ control keyboard

Video part:
M1: SM164A video matrix
2 monitors
3 cameras

Telemetry part:
R1, R2, R3: DTMRX2 Receivers
PT1, PT2, PT3: Pan & Tilt PTH910

One operator, with more than one monitor, controls a series of pan & tilt with receivers operating with telemetry on coaxial cable from the matrix:

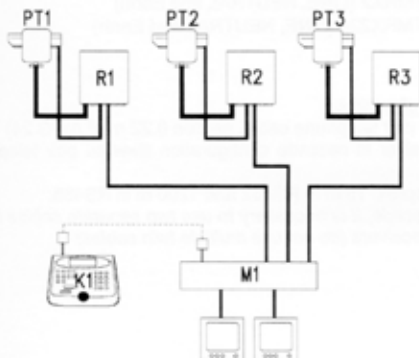

MATERIALS

Control part:
K1: DCJ control keyboard

Video part:
M1: SM164A video matrix
2 monitors
3 cameras

Telemetry part:
R1, R2, R3: DTMRX2 Receivers
PT1, PT2, PT3: Pan & Tilt PTH910

4.4 Cables



In the diagrams given as examples different types of lines have been used to show cables with different functions:



video cable:
coaxial RG 59 or equivalent cable.



multipolar cable:
each pan & tilt control function is activated /deactivated by a relay inside the receiver.
Determine the final number of cables by following the instructions given below:

- 7 wires for pan & tilt movements: right, left, up, down, autopan, common, earth
- 6 wires for lens control with reverse polarity (zoom, focus, iris)
- 4 wires for lens control with common wire (zoom, focus, iris)
- 2 wires for the auxiliary
- 3 wires for the power supply cable

Note: we advise the use of different multipolar cables for low voltage and high voltage functions.

Minimum recommended cross section:

- 0.56 mm² (AWG 20) for high voltage pan & tilt wires (DTMRX2 receiver)
- 0.75 mm² (AWG 18) for low voltage pan & tilt wires (DTMRX224 receiver)
- 0.34 mm² (AWG 22) for low voltage wires (lens, auxiliary)
- 0.75 mm² (AWG 18) for power supply wires DTMRX2 (LINE, NEUTRAL and Earth)
- 1.00 mm² (AWG 16) for power supply wires DTMRX224 (LINE, NEUTRAL and Earth)



cable for digital reception/transmission of controls:

2 wires for reception from the control unit (twisted pair telephone cable, section 0.22 mm² AWG 24)
2 wires for transmission, if any, to the next receiver in cascade configuration (twisted pair telephone cable, section 0.22 mm² AWG 24)

Note: the maximum length of the connection is approx. 15 m in RS232 and 1200 m in RS485.

When more than one receiver is connected in cascade, it is necessary to use two separate cables for reception and digital transmission of the controls between receivers (do not use multiple twin cables)

5 Installation



Installation must only be carried out only by skilled, authorised technicians.



The following procedures should be carried out with the power supply disconnected, unless indicated otherwise.

5.1 Opening the package

If the packing is not obviously damaged (due to dropping or abnormal scrapes and scratches), check the material contained in it against the list provided in the *Package contents* section of the *Introduction*.

The packing materials are completely recyclable. The installer will be responsible for disposing of them by recycling or according to the legislation in force in the country where the appliance is used.

5.2 Checking the markings



Before proceeding further with installation, check the identification labels to make sure the supplied material corresponds with the required specifications, as described in the section *Identification data*.

Never, under any circumstances, make any changes or connections that are not described in this manual: the use of inappropriate appliances may expose personnel and the system to serious safety hazards.

5.3 Configuration DIP switches and Jumpers



In the following diagram identify the configuration DIP switches and Jumpers:

Trimmer TR1 for adjusting lens voltage

RS232C JP1
RS485 JP2

BNC J1 and J2 for coaxial reception

Jumper JP4

Jumper JP3

Connector J4

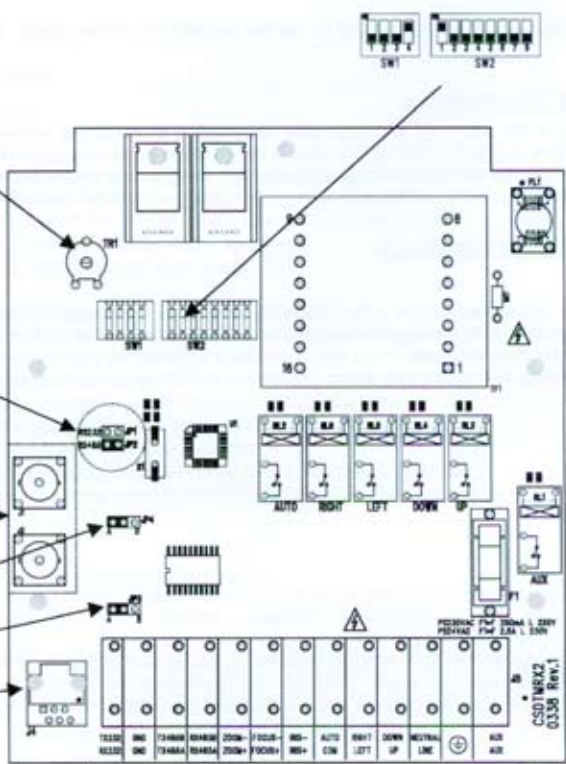

Screen printing for top row terminals

Screen printing for bottom row terminals

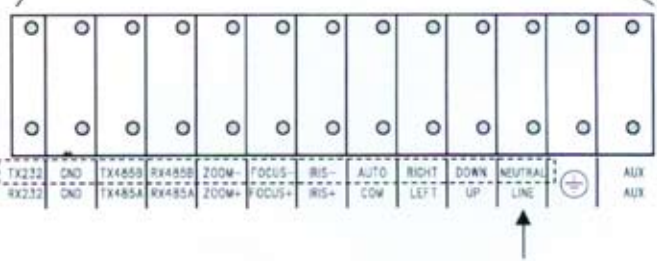

Terminals for receiver power supply



Note on terminal J5

Terminal J5 has a double row of connectors. The screen printing regarding the top row of connectors is that nearest to the related terminal (for example, NEUTRAL refers to the upper terminal) while the screen printing regarding the bottom row of connectors is that further away (for example COM refers to the lower terminal). To insert the connecting cables in the terminal board J5 use a flat screwdriver in the appropriate slots as shown in Figure 1.

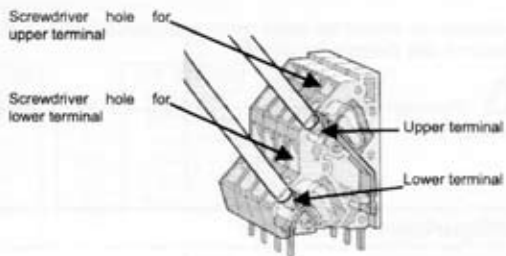



Fig. 1

6 Connecting the power supply

The connection should be made using the corresponding terminations of terminal J5 (LINE, NEUTRAL, ) as shown in the diagram on page 8.



Warning! When wiring up prepare the earth conductor to be 2-3 cm longer than the other conductors

7 Configuring the receiver



The configuration stage for the receiver makes it possible to set it up for optimum performance, according to system needs. Configuration must only be carried out at the installation stage by the installer technician.

We advise proceeding with parameter configuration in an orderly manner to prevent installation problems. The parameters that will be set at the configuration stage are:

- Receiver identification number (receiver address)
- Communication rate setting (1200, 9600, 19200 or 38400 baud)
- Receiver protocol setting (MACRO, Videotec, Pelco D or COAX)
- Auxiliary or Wiper setting
- Receiver reception mode (RS232/RS485/COAX)
- Load insertion on the RS485 line
- Lens connection
- Control unit connection
- Adjustment of lens control voltage
- Connection of pan & tilt and lens cables

7.1 Setting the receiver identification number

The receiver can be configured with an address between 1 and 99.

- make sure the power supply is disconnected (power supply LED off)
- configure the DIP switches of SW2 according to the following table :

	DIP SWITCH			DIP SWITCH			DIP SWITCH		
	1234	567		1234	567		1234	567	
01	++--	---		34	--+-	+-	67	++--	---
02	--+-	---		35	++--	+-	68	---	++-
03	++--	---		36	--+-	+-	69	+-	++-
04	--+-	---		37	+++-	+-	70	--+-	---
05	+++-	---		38	--+-	+-	71	+++-	---
06	--+-	---		39	+++-	+-	72	---	++-
07	+++-	---		40	----	+-	73	+++-	---
08	----	+-		41	+++-	+-	74	--+-	---
09	+++-	---		42	--+-	+-	75	+++-	---
10	--+-	---		43	+++-	+-	76	--+-	---
11	+++-	---		44	----	+-	77	+++-	---
12	----	+-		45	+++-	+-	78	+++-	---
13	+++-	---		46	--+-	+-	79	+++-	---
14	----	+-		47	++++	+-	80	---	++-
15	++++	---		48	----	+-	81	+++-	++-
16	----	++-		49	+++-	++-	82	--+-	++-
17	+++-	++-		50	--+-	++-	83	+++-	++-
18	--+-	++-		51	+++-	++-	84	--+-	++-
19	+++-	++-		52	----	++-	85	+-	++-
20	--+-	++-		53	+++-	++-	86	--+-	++-
21	+++-	++-		54	--+-	++-	87	+++-	++-
22	--+-	++-		55	+++-	++-	88	----	++-
23	+++-	++-		56	----	++-	89	+++-	++-
24	----	++-		57	+++-	++-	90	+++-	++-
25	+++-	++-		58	--+-	++-	91	+++-	++-
26	--+-	++-		59	+++-	++-	92	--+-	++-
27	+++-	++-		60	----	++-	93	+++-	++-
28	----	++-		61	+++-	++-	94	+++-	++-
29	+++-	++-		62	--+-	++-	95	+++-	++-
30	----	++-		63	++++	++-	96	----	++-
31	++++	++-		64	----	++-	97	+++-	++-
32	----	++-		65	+++-	++-	98	--+-	++-
33	----	++-		66	--+-	++-	99	+++-	++-

7.2 Setting the communication rate

The DTMRX2 (DTMRX224) receiver is able to carry out communications with four communication rates. Set DIP switches 1 and 2 of SW1 according to the following table:

DIP 1	DIP 2	Baud
OFF	OFF	9600 *
OFF	ON	19200
ON	OFF	1200
ON	ON	38400

* Default setting

7.3 Setting the receiver protocol

The DTMRX2 (DTMRX224) receiver is able to operate with four different types of protocol. Set DIP switches 3 and 4 of SW1 according to the desired type of protocol and referring to the following table:

DIP 3	DIP 4	Protocol
OFF	OFF	MACRO*
OFF	ON	Videotec
ON	OFF	Pelco D
ON	ON	COAX

* Default setting

Pelco D Protocol: the receiver sets a communication rate of 2400 baud, irrespective of the DIP 1 and DIP 2 settings for SW1.

7.4 Setting the auxiliary as Wiper

The DTMRX2 (DTMRX224) receiver allows the Auxiliary contact (AUX) to be set for Wiper operation (this function can only be activated from DCJ and DCT keyboards).

Normally the Auxiliary contact is activated from the keyboards with the AUX 1 command and is then deactivated with AUX 1. If Wiper mode is activated, the auxiliary contact will only operate when the Wiper key is pressed. When the wiper key is released the contact is deactivated.



The setting is made on DIP 8 of SW2 according to the following table:

DIP 8	Aux1 Function
OFF	Aux1*
ON	Wiper

* Default setting

7.5 Setting receiver reception mode (RS232/RS485/COAX)

Jumper JP1 and JP2 settings for RS485 reception: RS232  JP1
RS485  JP2

Jumper JP1 and JP2 settings for RS232 reception: RS232  JP1
RS485  JP2

For COAX reception (telemetry on coaxial cable) just set DIP switches 3 and 4 of SW1 as shown in the section on setting the receiver protocol.

7.6 Inserting the load on the RS485 line

NOTE: This setting is only necessary if a RS485 communication line is used.

To configure Jumpers JP3 and JP4, refer to the following settings:

 JP3
A B Jumper in position A

 JP4
A B Jumper in position B

Settings:
JP3 in position A: load inserted in RS485 transmission.
JP3 in position B: no load inserted in RS485 transmission.
JP4 in position A: load inserted in RS485 reception.
JP4 in position B: no load inserted in RS485 reception.

7.7 Connecting the control unit

The RJ11 connector present on the receiver (see J4 on page 8) is used for reception and transmission of digital data in RS485 or RS232 thus allowing a rapid connection with the keyboards during any test stages, or for connecting conversion interfaces that are available on the market (RS232-optic fibre).

For definitive connection with the keyboards, on the other hand, use the terminals present on the J5 terminal board. We advise using RS485 mode which is able to reach a maximum distance of 1200 metres and communication is immune to external interference. In COAX reception mode, on the other hand, it is possible to reach a maximum distance of 350 metres from the control unit (via SMXXA series matrixes). Lastly, in RS232 reception mode it is possible to cover a maximum distance of 15 metres from the control unit (PC or DCS2 and DCMT8 model keyboards).

7.8 Connection with the RS485 line

The DCJ, DCT, DCTEL keyboards and the DTMRX2 (DTMRX224) receiver can be connected directly by the telephone cable supplied with the keyboard and using the RJ11 (J4) connector present on the circuit. For a definitive connection between control unit and receiver, refer to the following procedure:



Keyboard – receiver connection

Connect the telemetry outlet of the keyboard to the RJ-JACK shunt box using the supplied telephone cable. Use a twisted pair cable to connect the receiver terminals marked by screen printing RX485A and RX485B to the RJ-JACK shunt box that has already been connected to the keyboard. Refer to the following diagram and the table below to make a correct installation:

RS485 communication mode: Maximum distance 1200 metres.

DCJ, DCT, DCTEL, DCIR (RJ11 A o B)	DTMRX2 DTMRX224
White TX-485A	RX485A
Yellow TX-485B	RX485B

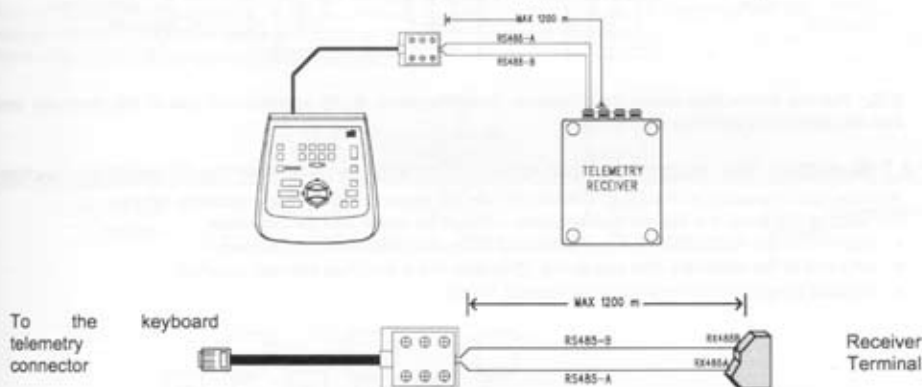

Three possible system installations are illustrated below:

- Point-to-point connection (in cascade)
- Multi-point connection (in parallel)
- Mixed connection

7.8.1 Connecting more than one receiver in cascade (point-to-point connection)

The DTMRX2 (DTMRX224) receivers are able to regenerate the received signal internally and retransmit it on a new communication line to the next receiver. Each of the three stages of the line (L1, L2, L3) is considered independent, and connects only two devices point-to-point, each with the load inserted, over a maximum distance of 1200 metres. The distance between keyboard K1 and receiver R3 may therefore reach 3600m (1200 m between keyboard K1 and receiver R1, 1200 m between receiver R1 and R2, and a further 1200 m between receiver R2 and receiver R3, for a total of 3600 m).

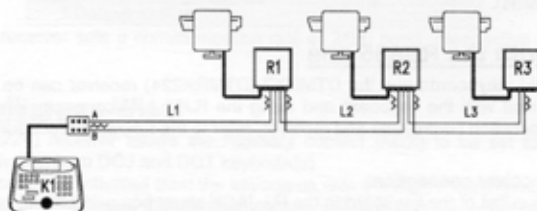

Note: Terminals RX485A and RX485B, which have the load inserted, should be connected to terminals TX485A and TX485B respectively on the previous unit, and these also have the load inserted. Terminals TX485A and TX485B with the load inserted should be connected to terminals RX485A and RX485B respectively on the subsequent unit (always with the load inserted):

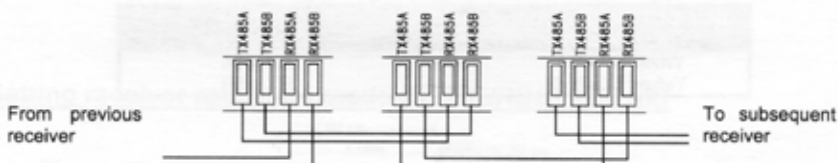

N.B.: For the connection under consideration (point-to-point), faulty operation of one of the receivers implies that the devices in cascade will be cut off.

7.8.2 More than one receiver per line, connection with twisted pair (multi-point connection)

All receivers connected to the same line should use the same communication protocol, RS485.

For each of the lines, the following observations should be taken into consideration:

- only one of the keyboards (the one at an end of the line) has the load inserted
- only one of the receivers (the one at the other end of the line) has the load inserted.
- the total length of the line should not exceed 1200m.

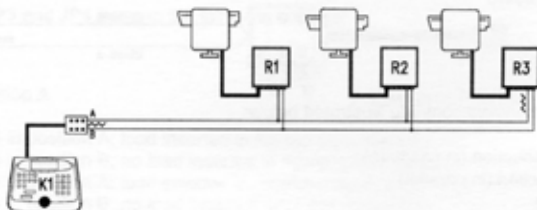

Line A of keyboard K1 has been used for communication with the telemetry. The ends (Keyboard K1 - Receiver R3) should have the termination resistance inserted. Receivers R1, R2, should not have the termination resistance inserted. The maximum length of the line, from end to end (from keyboard K1 to receiver R3), is 1200 metres.

N.B.: For the connection in question (multi-point), faulty operation of one of the devices does not influence the other receivers.

7.8.3 Mixed configurations (point-to-point /multi-point)

This is a combination of the two previous connection methods and, depending on the chosen combination, makes it possible to exploit to the full the advantages of the two types of connection, also significantly reducing the probability of faulty operation. The following is an example of mixed connection:

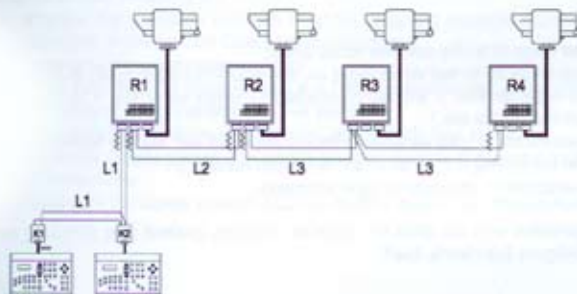

In the example shown, if receiver R3 is blocked (connected in multi-point on line L2) it does not cause a malfunction in receiver R4. R3 is not at the ends of line L3 and therefore should not be terminated. If receiver R2 fails, because this is the 'generator' of line L3 all receivers connected to it in cascade (R3 and R4) will not receive the controls.

7.9 Connection with the RS232 line

The DTMRX2 (DTMRX224) receiver can be controlled by means of a RS232 line from a PC or from keyboards that integrate RS232 communication (DCS2 and DCMT8). Bear in mind that the maximum distance with the RS232 serial line is 15 metres. Refer to the following connection table.

DCS2/DCMT8 RJ-JACK		DTMRX2
Black Tx RS232	-----	RX232
Green GND RS232	-----	GND

For connecting the receivers in cascade, connect terminal RX232 to terminal TX232 of the previous unit and connect terminal TX232 to terminal RX232 of the subsequent unit. Connect the earths together (GND). In any case refer to the following connection diagram:

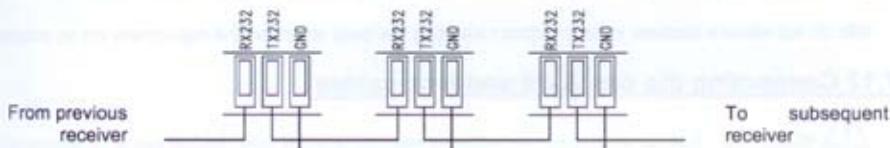

7.10 Connection for reception by coaxial cable (COAX)

The DTMRX2 (DTMRX224) receiver integrates telemetry reception on coaxial cable (RG59 or equivalent). The maximum distance that can be reached by a coaxial communication is 350 metres (Matrix – Camera distance). It is not possible to insert video signal amplification devices (video distributors for example). To configure the system correctly:

- Connect BNC J1 on the receiver (see page 8) to the camera video outlet.
- Connect BNC J2 on the receiver (see page 8) to the video input on the matrix corresponding to the address setting in the receiver (for example receiver No. 1 will be connected to video input No. 1 on the matrix, receiver No. 2 to video input No. 2 on the matrix etc.)
- Set DIP switch SW1 for COAX communication (see receiver protocol settings) and set the receiver address with DIP switch SW2 (see the section on setting the receiver identification number).
- Set the matrix (and the keyboard if necessary) with coaxial type telemetry.

NOTE: COAX communication is only possible with the SMXXA (SM42A, SM82A, SM84A and SM164A) model matrices. Refer to its own manual to configure the matrix itself.

7.11 Type of controlled lenses and adjusting the lens control voltage



WARNING: Failure to connect the type of lenses correctly could cause damage to the lenses themselves.

The DTMRX2 (DTMRX224) is able to control both reverse polarity and common wire lenses. For lenses operating with a common wire, connect the common wire to FOCUS –

Adjusting the lens control voltage

- insert a load between terminals FOCUS+ and FOCUS- that absorbs at least 10mA (use a resistance sized between 100 and 1000 ohm).
- connect the power supply cable and power the DTMRX2 or DTMRX224 unit (power supply LED on)
- position the tester prods on terminals FOCUS+ and FOCUS-
- keep the FOCUS NEAR button on the control unit pressed
- adjust the lens control voltage by adjusting trimmer TR1 (see diagram page 8; default 12V \approx)

NB: do not adjust a loadless voltage (without inserting the load) otherwise the adjustment will be incorrect.

7.12 Connecting the pan & tilt and lens cables



WARNING: Before carrying out the following operations make sure that the pan & tilt control voltage and the setting for lens type are correct

- Disconnect the power supply to the unit
- Make the connections with the lens and pan & tilt
- Power the unit

N.B.: We recommend using flexible cables with an appropriate cross section (see the section on cables).

8 Switching on and off



Before switching on:

- examine the markings to make sure the supplied material corresponds with the required specifications, as described in the section *Checking the markings*.
- make sure the safety fuse is intact
- make sure that the receiver and the other components of the system are closed and there is therefore no possibility of direct contact with live parts.
- make sure that all parts are fastened down firmly and safely
- the power supply cables should not hamper normal operations on the part of the installer technician or pan & tilt movements
- make sure the power source and connecting cables are able to handle the system's power consumption

9 Maintenance



The DTMRX2 (DTMRX224) receiver does not require any particular maintenance. When using it we recommend it rests on a solid base, with the power supply and connecting cables positioned so as not to get in the way of the operator.

10 Troubleshooting

A great feature of the DTMRX2 (DTMRX224) receiver is that it is very easy to use, nevertheless some problems could arise at the installation or configuration stage, or in use.

PROBLEM	PROBABLE CAUSE	REMEDY
<i>Power supply LED off</i>	<ul style="list-style-type: none">• No power• Fuse blown	<ul style="list-style-type: none">• Check the power supply cable• Replace fuse F1
<i>Controls in RS485 are not carried out and the power supply LED is on</i>	<ul style="list-style-type: none">• Incorrect configuration for reception• Incorrect baud rate or protocol• Incorrect receiver address• Incorrect wiring	<ul style="list-style-type: none">• Check the settings of Jumpers JP2 and JP4.• Check the settings of DIP Switch SW1• Check the address setting in the receiver (DIP SW2)• Check the wiring to terminals RX485A and RX485B of J5
<i>Controls in RS232 are not carried out and the power supply LED is on</i>	<ul style="list-style-type: none">• Incorrect configuration for reception• Incorrect baud rate or protocol• Incorrect receiver address• Incorrect wiring	<ul style="list-style-type: none">• Check the setting of Jumper JP1• Check the settings of DIP Switch SW1• Check the address setting in the receiver (DIP SW2)• Check the wiring to terminals RX232 and GND
<i>Controls in COAX mode are not carried out and the power supply LED is on</i>	<ul style="list-style-type: none">• Incorrect configuration for protocol• Incorrect configuration for receiver address• Incorrect wiring	<ul style="list-style-type: none">• Check DIP switch SW1• Check the settings of DIP Switch SW2 and make sure the address setting corresponds to the input video channel of the SMXXA matrix• Check the coaxial cable (maximum length 350 m). Do not use video amplification devices between matrix, receiver and camera.
<i>Pan & tilt does not work</i>	<ul style="list-style-type: none">• Incorrect pan & tilt power supply	<ul style="list-style-type: none">• Make sure the power supply voltage for pan & tilt corresponds to that supplied by the receiver
<i>The lens does not work</i>	<ul style="list-style-type: none">• Incorrect lens voltage	<ul style="list-style-type: none">• Check adjustment of trimmer TR1
<i>In a cascade connection, subsequent units do not receive the controls</i>	<ul style="list-style-type: none">• Incorrect connection• Incorrect configuration for reception• Incorrect baud rate or protocol• Incorrect address	<ul style="list-style-type: none">• Check the connecting cables• Check the Jumper settings• Check the setting for SW1• Check the address settings in the units that are not working

11 Technical specifications

General specifications

Maximum capacity of RS485 telemetry line	1200 m
Maximum capacity of RS232 telemetry line	15m
Maximum capacity for COAX reception	350m
Capacity of Auxiliary Contact	1A 230V~ / 1A 24V~
Maximum number of addressable receivers	99
Lens voltage adjustment	3 ⁻⁻⁻⁻ - 14 V ⁻⁻⁻⁻ max 100mA
Maximum consumption	10 W
Maximum switchable power	100 W
Operating temperature	From -20 °C to +50°C
IP protection rating	IP56
Net weight	850 g
Dimensions	225 (L) x 154 (W) x 81 (H) mm
Conformity	EN55022 classe B, EN50130-4 EN60065, FCC part 15 Class B

Technical specifications for the DTMRX2 receiver

Power supply voltage	230V~ 50Hz
Pan & tilt power supply voltage	230V~ 50Hz
Fuse F1	F 250mA L 250V

Technical specifications for the DTMRX224 receiver

Power supply voltage	24V~ 50/60Hz
Pan & tilt power supply voltage	24V~ 50/60Hz
Fuse F1	F 2.5 A L 250V