



VEILUX[®]
The Art of Surveillance

VSIP-2

Dual Codec (Megapixel) IP camera



Features

- Dual codec (H.264 & MJPEG)
- Multi-profile video streaming
- Digital PTZ
- Analog CVBS output
- Standard PoE(IEEE802.3af)
- Bidirectional audio communication
- 3 Axis lens mount

Phone # 1-800-510-6528 website: www.Veilux.net

Directions

Be careful not to cause any physical damage by dropping or throwing Veilux VSIP-2.

Especially keep the device out of reach from children.

Do not disassemble Veilux VSIP-2. No After Service is assumed when disassembled.

Use only the power adapter provided with Veilux VSIP-2.

Be careful to prevent moisture or water penetration into the unit. Particular attention is needed when installing Veilux VSIP-2. The screw holes for the installation screws and pipe should be maintained water tight during the whole life time of the product.

All the electrical connection wires running into the unit should be prepared so that water from the outside cannot flow into the unit through the surface of the wires. Penetration of the moisture through the wire for extended period can cause malfunction of the unit or deteriorated image.

Note

This equipment has been tested and found to comply with the limits for a Class A digital device, pursuant to part 15 of the FCC Rules. These limits are designed to provide reasonable protection against harmful interference in a residential installation. This equipment generate, uses and can radiate radio frequency energy and, if not installed and used in accordance with the instructions, may cause harmful interference to radio communications. However, there is no guarantee that interference will not occur in a particular installation. If this equipment does cause harmful interference to radio or television reception, which can be determined by turning the equipment off and on, the user is encouraged to try to correct the interference by one or more of the following measures:

- Reorient or relocate the receiving antenna.
- Increase the separation between the equipment and receiver.
- Connect the equipment into and outlet on a circuit different from that to which the receiver is connected
- Consult the dealer or an experienced radio/TV technician for help.

Caution

Any changes or modifications in construction of this device which are not explicitly approved by the party responsible for compliance could void the user's authority to operate the equipment.

Revision History

Date	Revision	Details
2010-01-08	1.0	First manual revision creation.
2010-04-19	1.1	Addition of windows vista and 7 in trouble shooting

Contents

Contents 4

1. Introduction 5

 1.1. Overview 5

 1.2. Specification 6

 1.3. Applications of Veilux VSIP-2 8

2. Product Description..... 9

 2.1. Contents 9

 2.2. Product Preview 10

 2.3. Physical description 11

 2.4. Functional Description 12

3. On Site Installation..... 16

 3.1. Stand Bracket 16

4. Getting Started..... 17

 4.1. PC Requirement..... 17

 4.2. Quick Installation Guide 18

5. Trouble Shooting 22

 5.1. No power is applied..... 22

 5.2. Cannot connect to the Video 23

 5.3. Windows Vista or Windows 7 24

 5.4. Technical Assistance 27

1. Introduction

1.1. Overview

The Veilux VSIP-2 is a state-of-the-art (Megapixel), multi-codec (H.264, MJPEG) IP camera (or network camera) built with embedded software and hardware technology. It enables real time transmission of synchronized video of up to 2 (Megapixel)s and audio data. Remote clients can connect to Veilux VSIP-2 for the real time video/audio data through various client solutions running on PC, PDA or mobile phones. Real time 2-way communication is available through bidirectional audio communication feature.

Designed to be a stand-alone streaming audio & video transmission device, Veilux VSIP-2 can be applied to various application area such as video security, remote video monitoring, distance education, video conference or internet broadcasting system.

Embedded PoE (Power over Ethernet, IEEE 802.3af) will enable the owner to reduce TCO (Total Cost of Ownership) by reducing on-site wiring works for the installation.

1.2. Specification

Category	Sub-Category	Details	
Video	Compression	H.264/MJPEG	
	Resolution	**Refer to the datasheet.	
Audio (Bi-directional)	Up	32 Kbps G.726	
	Down	64 Kbps PCM	
Network	Interface	RJ-45, 10/100 Mbps, PoE (802.3af)	
	Access network	Static, DHCP, PPP/PPPoE	
	Application	RTP, RTSP, SMTP, FTP, HTTP, SDP, NTP, DNS	
I/O	RS-485	For providing RS-485 device	
	Sensor In	1	NC, NO Selectable
	Relay Output	1	For alarm annunciation or remote ON/OFF control (30V, 1A)
	RS-232C	For factory use only	
	Mic/Line In	Selectable in Admin page	
	Line Out	1 V p-p output for amplified speaker	
	CVBS output	For temporal use during installation	
Power Supply	PoE	Power over Ethernet (IEEE802.3af)	
	DC Adaptor	12V DC adaptor (2A)	
Mounting	Stand Bracket		
Motion Detection	3 zones	Arbitrary shape with independent sensitivity	
Upgrade	Firmware upgrade over IP network		
Administration	Remote administration over IP network		
Client & Viewer	Web Viewer	Simple viewing over internet explorer	
	NVR-Pro	Standard CMS software	
	3rd Party CMS	Ask Veilux for details	
Dynamic IP support	DDNS support	Supported	
Security	Video/Audio stream encryption		
	ID and Password protection		

	IP filtering for restricting administrative access for audio and bi-audio	
Time management	Sync to PC	Synchronize to PC
	Manual	Manual time setting
	Internet Time Server	Synchronize to Time Server
	DLS	Day Light Saving
SDK support	Active-X	
	HTTP	

1.3. Applications of Veilux VSIP-2

- Security surveillance (buildings, stores, manufacturing facilities, parking lots, banks, government facilities, military, etc.)
- Remote monitoring (hospitals, kindergartens, traffic, public areas, etc.)
- Teleconference (Bi-directional audio conference). Remote Learning, Internet broadcasting
- Weather and environmental observation

2. Product Description

2.1. Contents

The product package contains followings:

Contents	Description	Remarks
Veilux VSIP-2	IP camera (Veilux VSIP-2) main unit	
Power Adaptor	Default built in standard PoE module (IEEE802.3af)	12VDC Adaptor (Optional item)
Mounting bracket	Standard mount bracket	Supported
CD	Software & User's Guide	
Quick Reference Guide	Quick installation guide	

2.2. Product Preview

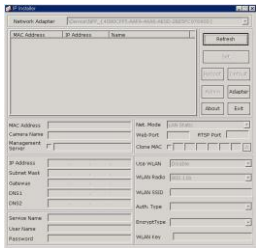
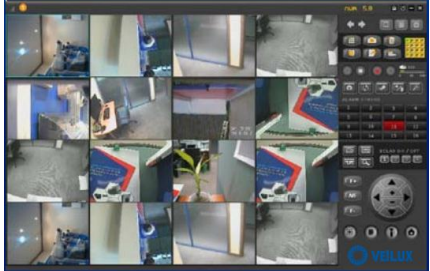
Veilux VSIP-2	IP-Installer	CMS Software (NVXR-64)
		
<p>Mega pixel IP Camera</p>	<p>PC software to allocate an IP address to the IP Camera</p>	<p>PC software to view and record the A/V streaming data transmitted from IP camera. (Simultaneous support of up to 16 IP cameras)</p>

2.3. Physical description

2.3.1. External View



Figure 2-1. External view of Veilux VSIP-2

2.3.2. Rear panel

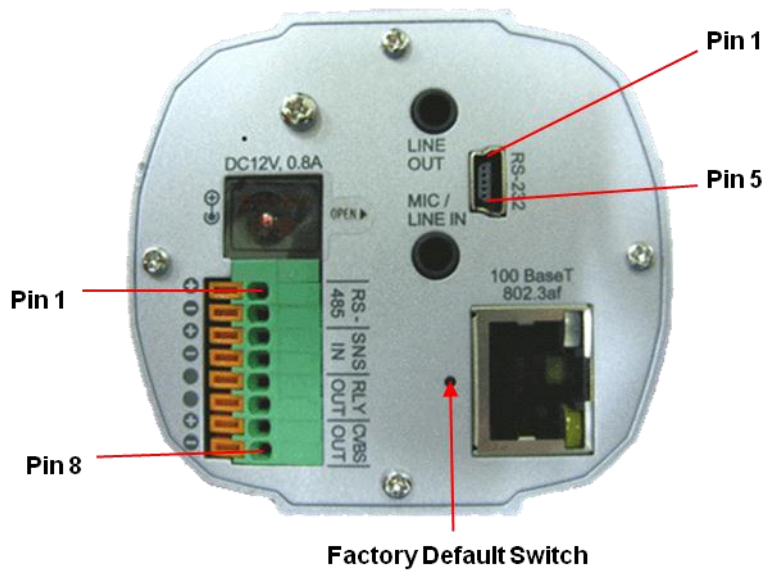

Figure 2-2. Rear panel of Veilux VSIP-2

2.4. Functional Description

- **DC 12V:** Power input for supplying 12V DC power.



Caution: If Veilux VSIP-2 is powered by PoE, do not plug in DC Jack with active DC power into DC power connector.

- **MIC/LINE IN**

Connect external audio source or microphone.

- **Line Out**

Connect speakers with built in amplifier. Audio from remote site is output through Line out in bi-directional audio mode.

- **100Base-T**

100Mbps Ethernet connector (RJ-45) with PoE standard (802.3af). 2 LEDs on the Ethernet connector shows the status of Veilux VSIP-2 as the followings:

- **Status LED (Dual Color - Red/Green):** It will be lit in green or red depending on the status.
 - ① Green: Green color indicates that the camera is in normal operation mode. Continuous green indicates that data transmission is possible. Blinking green means that someone is connected to Veilux VSIP-2.
 - ② Red: Continuous or blinking red indicates that hardware is in abnormal condition.



Red/Green LED will be lit with red momentarily and it will be lit with green after a while when power is applied into Veilux VSIP-2

- **LINK/LAN LED (Orange)**

It will be lit with orange color when network cabling is all right. Blinking orange color indicates that normal data transmission is under way. Off state indicates that there is trouble in network connection.

- **RS-232C**

3 Pins on the right of the connector are assigned for RS-232 port. Please note that leftmost pin is numbered as 1.

Pin	Description	Misc.
1	Not used	
2	Not used	
3	RxD (Connect to TxD of the other end)	For debugging & factory use only.
4	TxD (RxD (Connect to RxD of the other end))	
5	Ground of RS-232C	

• ALARM IN/OUT and Composite Video Output

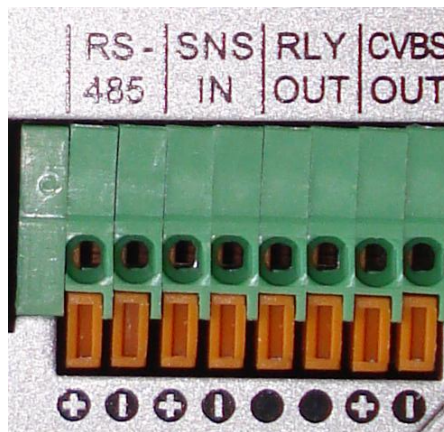

Figure 2-3 Terminal block for the I/O Connection of Veilux VSIP-2

Used for connecting P/T device, sensor, and composite video output. Pin assignments are as follows.

Pin	Description	Misc.
1	RS-485 Plus (+)	For providing RS485 signal to RS485 devices
2	RS-485 Minus (-)	For providing RS485 signal to RS485 devices
3	SNS IN (+)	Sensor In (+): NC/NO selectable in admin mode
4	SNS IN (1)	Sensor In (-): NC/NO selectable in admin mode
5	RLY OUT	Relay output: Closed circuit in alarm to indicate alarm status
6	RLY OUT	
7	CVBS OUT(+)	Composite output of analog video
8	CVBS OUT(-)	Ground connection for Composite output of analog video

■ RS-485

Used for connecting Pan/Tilt devices having RS-485 interface standard.

■ **SNS IN**

Examples of sensing devices are infrared sensors, motion sensors, heat/smoke sensors, magnetic sensor, etc. Connect the two wires of the sensors to “SNS In”. The sensor type (NC/NO) can be set in Administrative mode. 10mA can be flown into sensor device. Multiple sensor devices can be connected in parallel.

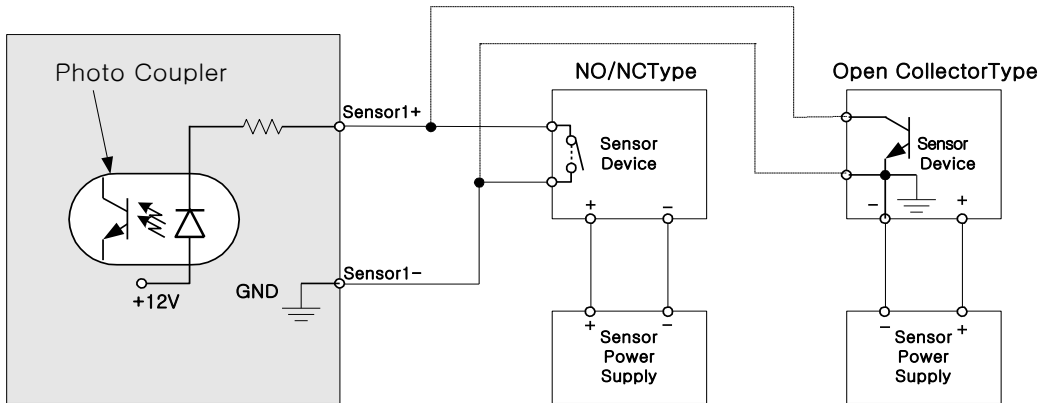

Figure 2-4. SENSOR Input connection

■ **RLY OUT**

It is used for connecting external alarm generators such as sirens, flashing light, etc. When activated, relay output configures a closed circuit.

A Relay output is provided for connecting alarm devices or for remote on/off devices such as light.. Relay is normal open and it will be closed upon alarm annunciation or remote on. The relay is capable of switching 30V AC/DC, 2A.

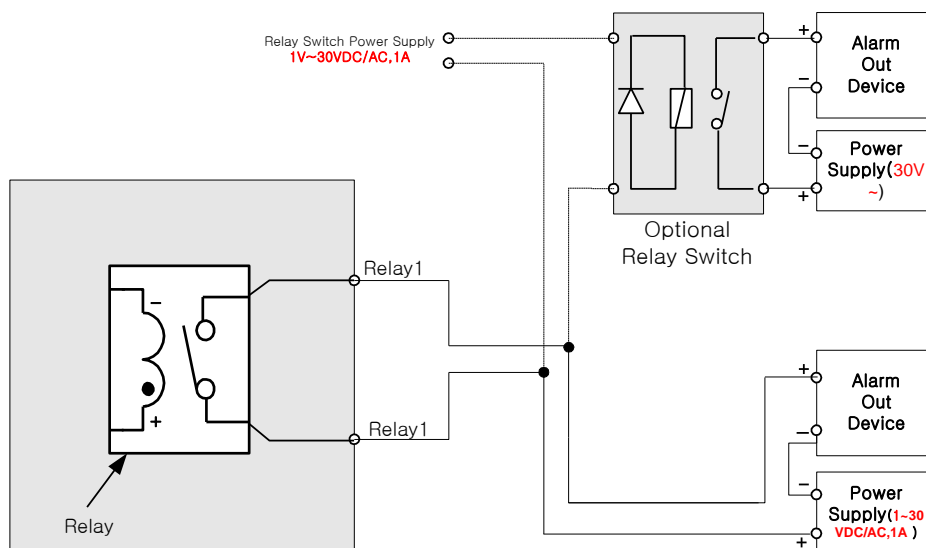
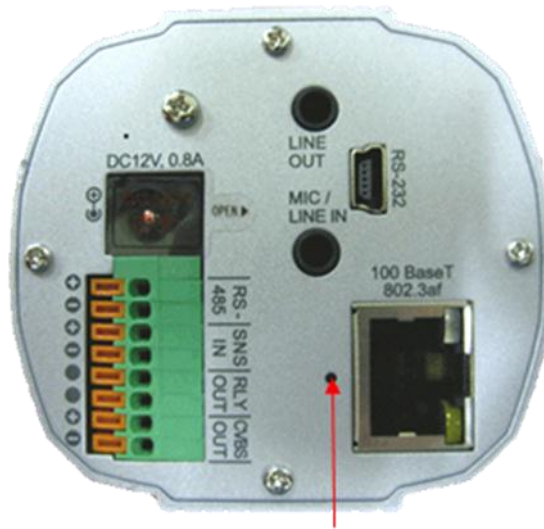

Figure 2-5. RELAY Output connection

• **Factory Default Switch**

A switch provided for returning the IP camera to factory default state. Press the switch for a few seconds while power is applied.



Factory Default Switch

Figure 2-6 Factory Default switch of Veilux VSIP-2



Restoring the factory default will erase all settings.

3. On Site Installation

3.1. Stand Bracket

Please follow through the following procedures for the installation on the wall or ceiling.



1. Fix the mounting bracket and bracket holder on the wall or the ceiling using screws.
2. Insert the bolt on the bracket into the bracket hole and rotate the bolt clockwise to install the IP camera on the bracket

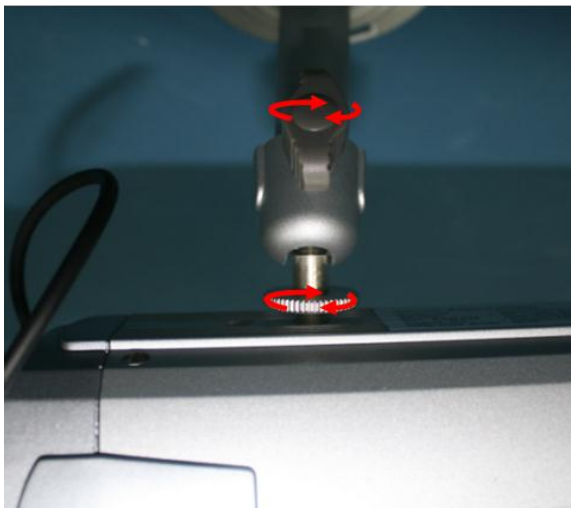

3. Rotate the nut and lever clockwise to tighten.

4. Getting Started

Brief information for first time operation of Veilux VSIP-2 is provided in this chapter.

4.1. PC Requirement

Audio/Video streaming data received from Veilux VSIP-2 can be displayed or stored in a PC running client programs. Minimum requirement of the PC is described below:

	Recommended	Remark
CPU	Pentium IV 3G above	
Main Memory	1GB above	
Operating System*	Windows XP, Vista, 7 (32 Bit)	
Web Browser	Internet Explorer 6.0 above	
Graphic Card	64M above	Higher than 1600x1200
Network	100 Base-T Ethernet	

* Operating Systems supported: Windows 2000 Professional, Windows XP / Vista / 7 (32 Bit)

4.2. Quick Installation Guide

1. Connect PC and Veilux VSIP-2 to network.

- 1) Prepare a PC to run programs for the installation and video connection
(PC is needed to assign IP address to Veilux VSIP-2)
- 2) In case of using PoE, connect the PC and Veilux VSIP-2 to the network using one of the following ways.
If your LAN Switch does not support standard PoE, connect Veilux VSIP-2 as shown in dotted line in Figure 4-1. The DC power is applied through DC adaptor.



Figure 4-1. Power and network connection

2. Install "IP installer and set IP parameters on Veilux VSIP-2

Insert the CD provided with product into the PC. Install WinPcap and IP Installer in sequence. Make sure that IP Installer can't run without WinPcap.



IP installer Ver. **3.0.1 or later** is needed in the configuration of Veilux VSIP-2.

Follow the sequence below for setting the IP parameter

- i) Run IP installer > Select Network Adaptor >OK
- ii) Click ① in IP installer window.> Double click on ②> Fill in ④> make a selection in ⑤> Fill the parameters in ⑥
- iii) Click on ⑨ to apply the settings.
- iv) You can connect to admin page by clicking on ⑩

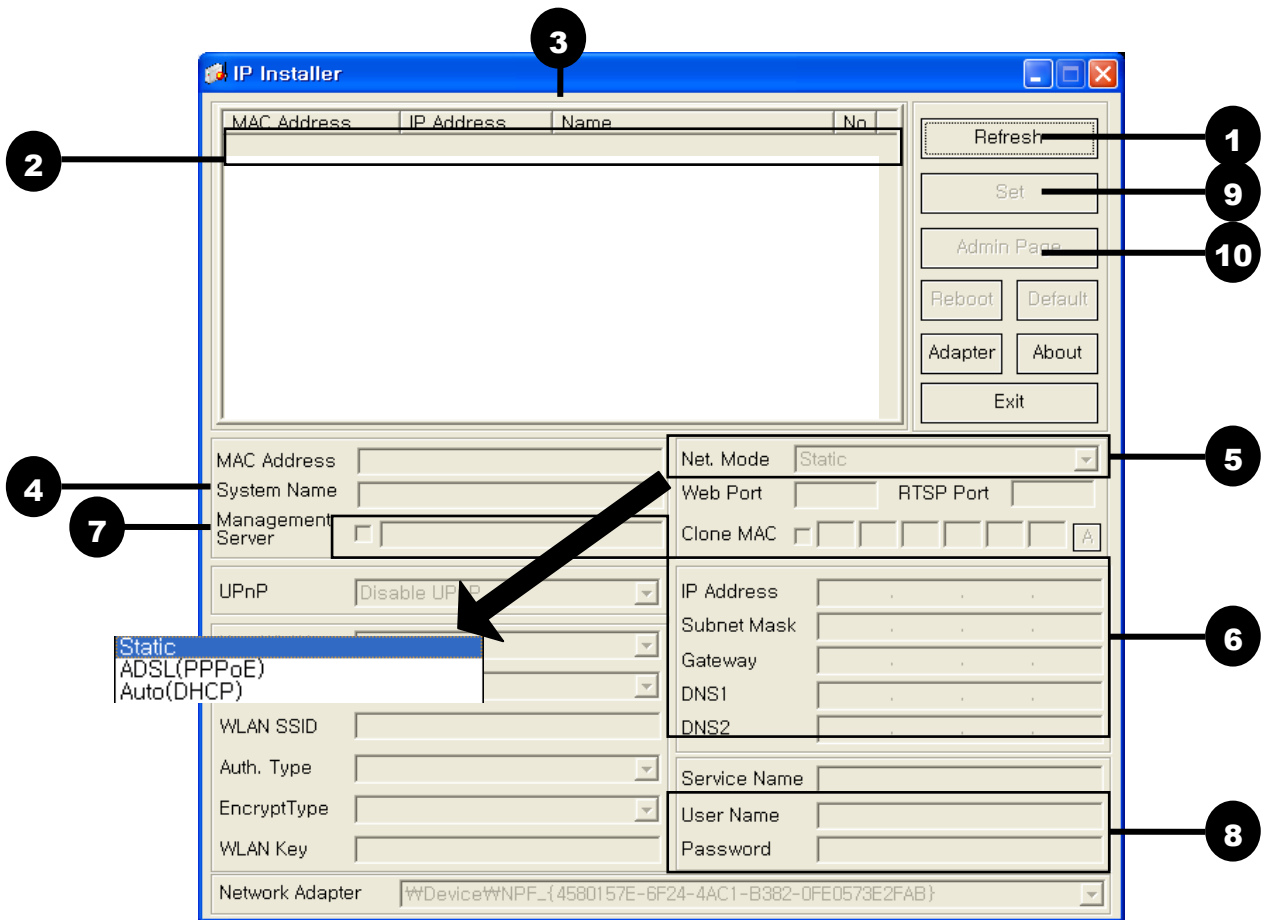

Click on the field in (3) for sorting and rearranging the list.

Select network mode that best suits your case from the drop down list in (5) You can choose either Static or ADSL and Auto (DHCP), respectively. If ADSL and Auto are selected, the fields in (6) is deactivated.

In case of ADSL, fill the User Name and Password in (8) with the values provided by your ISP.

If DDNS service is needed, do the followings:

- i) Check at the box and fill the empty field with mgmt.net-video.net in (7)
- ii) Register the IP camera on DDNS. Visit <http://www.net-video.net> for the registration.

If you don't have an account on www.net-video.net, open an account and register the IP camera after login.

3. Remote video connection to Veilux VSIP-2

1) Connection through Web Viewer

Web Viewer offers simplest way of video connection to Veilux VSIP-2. For video connection, enter the IP address of Veilux VSIP-2 in the URL window of Internet Explorer as:

[e.g.] Port 80

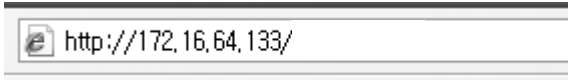

Can be omitted the default port of 80

[e.g.] Port 8080

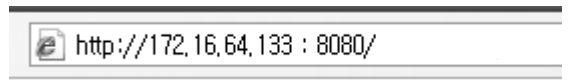

Note: Active-X module should be installed on your PC before actual connection. If your PC is not connected to the internet, you cannot download Active-X module. Most convenient way of installing the Active-X module is installing NVR-pro which is available from the CD or our web site.

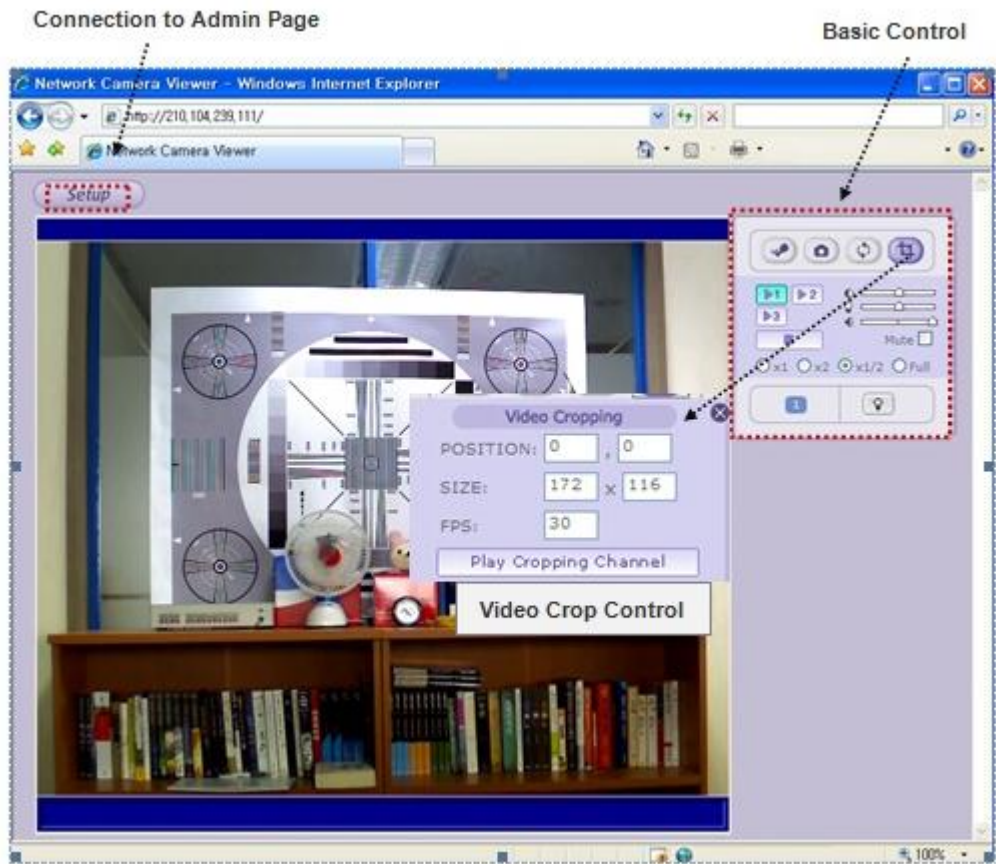

Figure 4-2. Web Viewer

Default ID and password of Admin Page are **root, admin**.

Phone # 1-800-510-6528 website: www.Veilux.net

2) Connection through NVXR-64

NVXR-64 is a multi-channel CMS program for to IP camera or Video server. Install NVXR-64 on remote PC to connect to these products. It is needed to assign connection information to NVXR-64 program before connection. Details for the NVXR-64 can be found in **[NVXR-64 User's Guide]**.

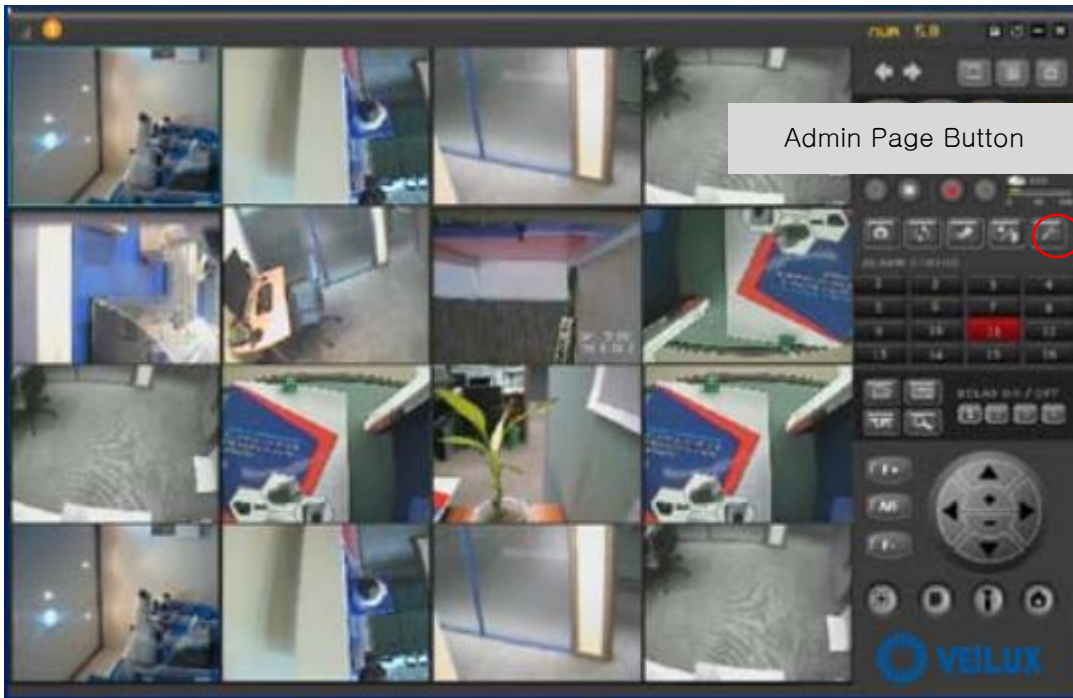

Figure 4-3. NVXR-64

4. Additional settings through connection to the Admin Page

All the parameters of new IP camera follow factory default values. For more sophisticated target application it is needed to change parameters. The admin page can be connected through

"http://IP address:HTTP port number"/admin.htm

It is needed to enter ID and password of the administrator. Default ID and password are **root, admin**. It is highly recommended to change the ID and password to prevent illegal access to the IP camera.

5. Trouble Shooting

5.1. No power is applied

- In case of Standard PoE (Power over Ethernet)

Power supply through standard PoE is possible only when the following conditions are met.

1. Standard PoE is supported on the product.
2. The LAN switch supports standard PoE.

Make sure that both the IP camera and the LAN switch support standard PoE (IEEE 802.3af)

- In case of DC adaptor

If PoE is not applied, the power and network connection should be made through separate cables. It is recommended to use DC adaptor supplied by Veilux for the feeding of the power. In case of replacing the DC power supply, make sure that the power supply meets with the power requirement of the IP camera to prevent damage or malfunction.

5.2. Cannot connect to the Video

Check the status of the network connection through PING test.

Try the following on your PC:

- Start > Run > Cmd > Ping IP address (Ex : Ping 172.16.42.51)
- If “Reply from ~” message is returned (① in the figure below), the network connection is in normal state. Try connection to the video again. If the problem persists, or refer to other trouble shooting notes.
- If “Request timed out” message is returned (② in the figure below), the network connection or network setting is not in normal state. Check the network cable and settings.

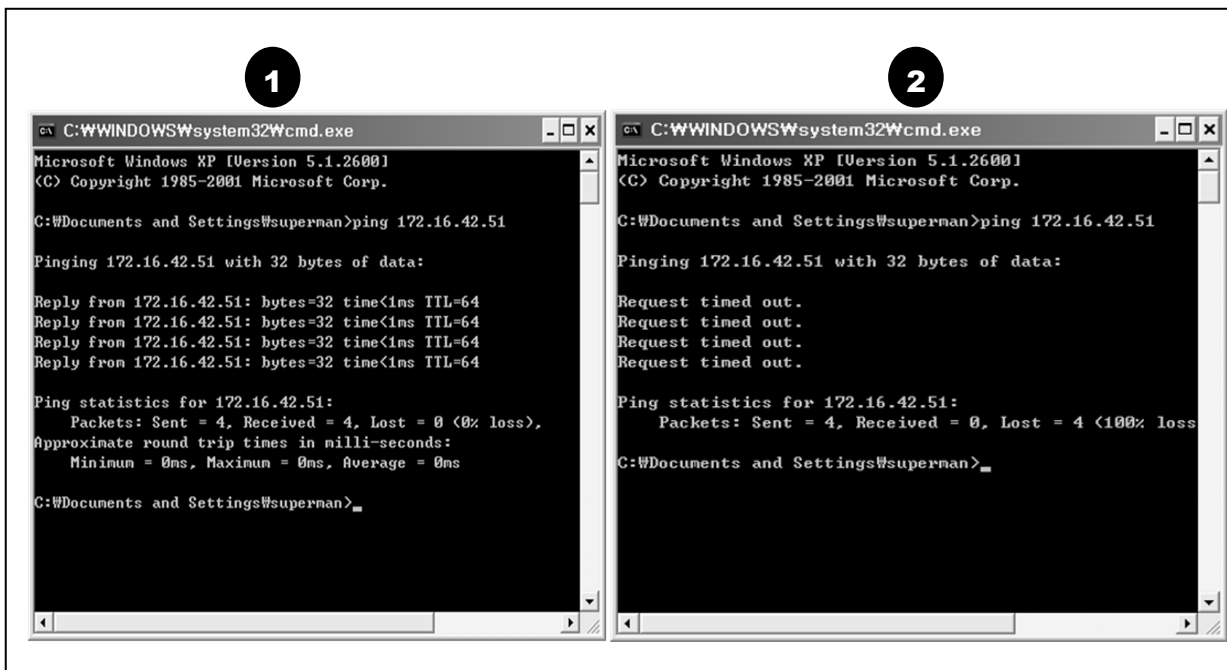

5.3. Windows Vista or Windows 7

Windows Vista and Windows 7 users need to configure UAC (User Access Control) and Privilege Level for proper recording and still video capture in NVXR-64 and Web Viewer.

<Windows Vista>

1. UAC (User Access Control) configuration

- 1) Double-click "User Accounts" in control panel
- 2) Double-click "Turn User Account Control on or off"
- 3) Uncheck "Use UAC to help protect your computer"

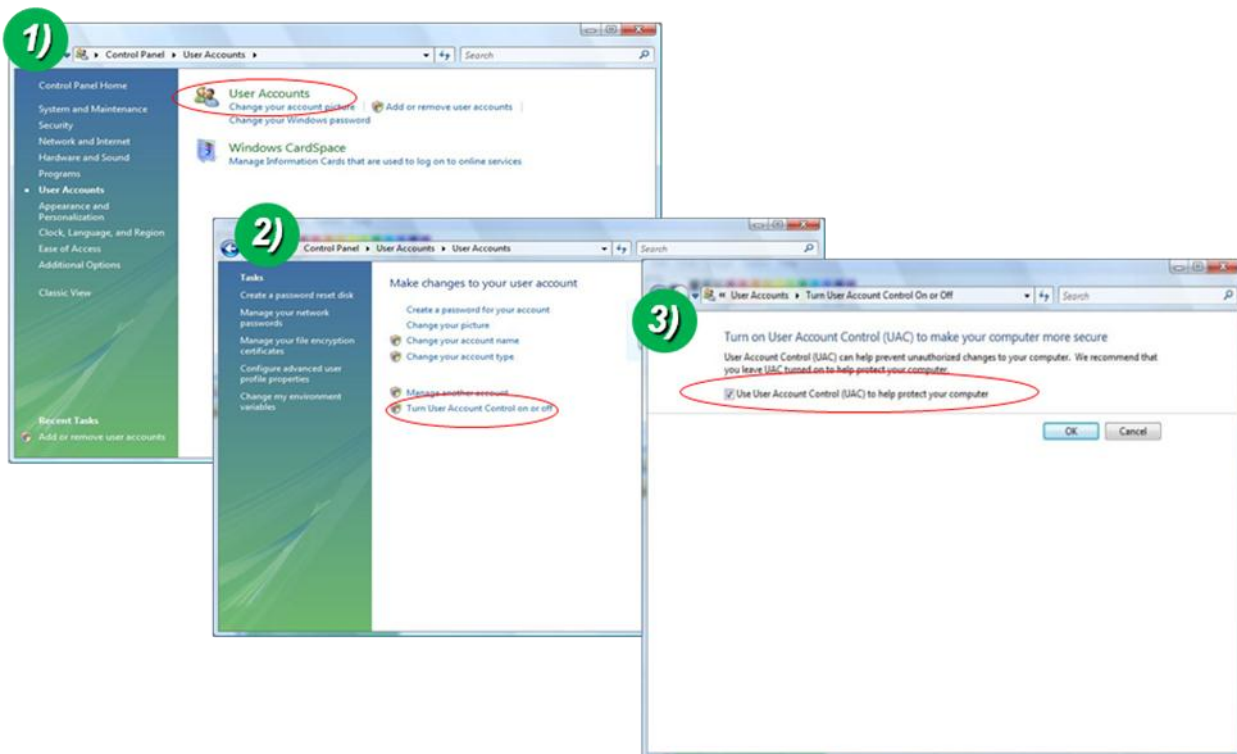

2. Privilege Level Control

- 1) Select "NVXR-64" icon on the desktop
- 2) Click right mouse button and select "Properties"
- 3) Check "Privilege Level" in "Compatibility" tab

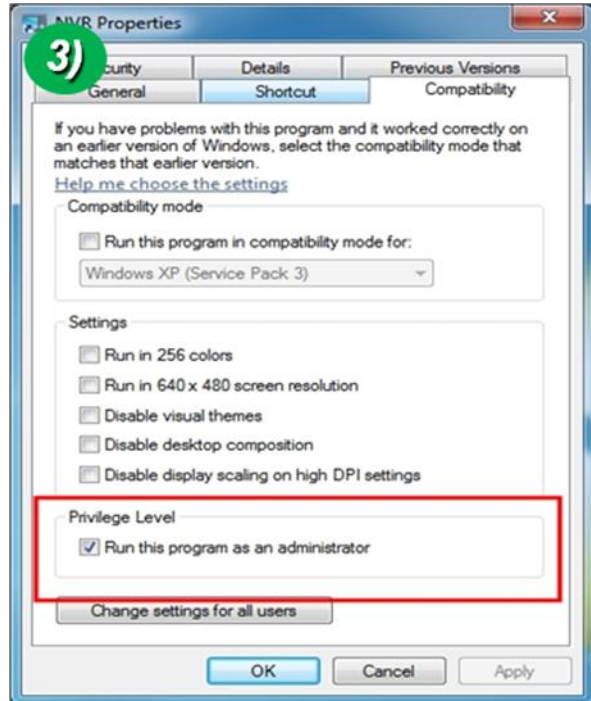
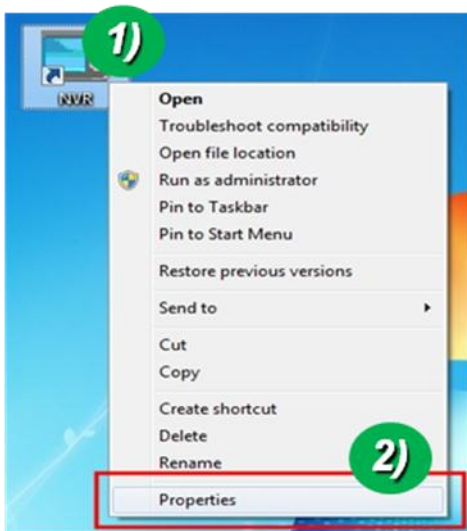

<Windows 7>

1. UAC (User Access Control) configuration

- 1) Double-click "User Accounts" in control panel
- 2) Double-click "Change User Account Control setting"
- 3) Set to "Never notify"

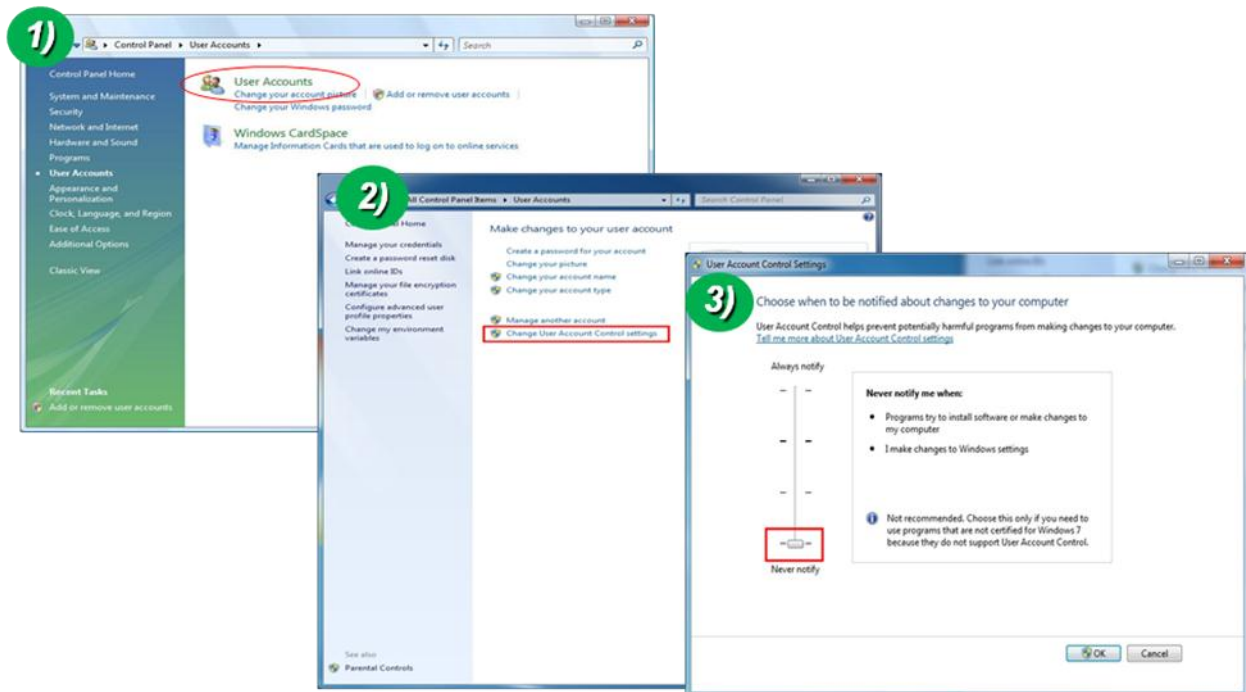

2. Privilege Level Control

- 1) Select "NVXR-64" icon on the desktop
- 2) Click right mouse button and select "properties"
- 3) Check "Privilege Level" in "Compatibility" tab

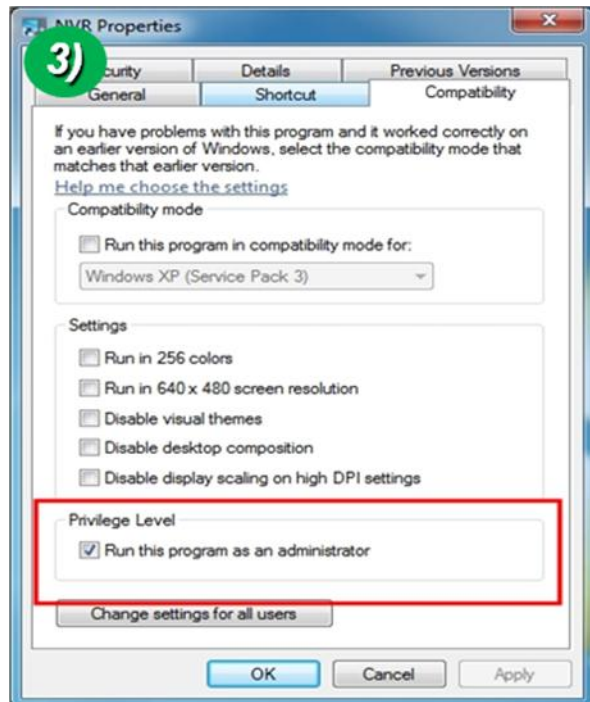
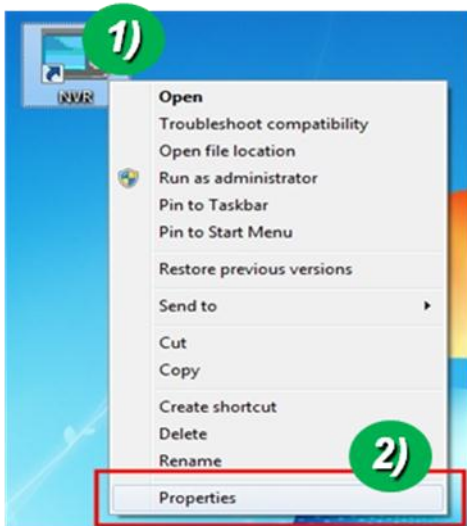

5.4. Technical Assistance

If you need any technical assistance, please contact your dealer. For immediate service please provide the following information.



1. **Model name**
2. **MAC address and Registration number**
3. **Purchase date**
4. **Description of the problem**
5. **Error message**