



Ex-mark: Exd IICT6/ DIP A20 TA.T6

License: XK06-123-00251

Certificate: CNEx07.1032X

# MANUAL BOOK

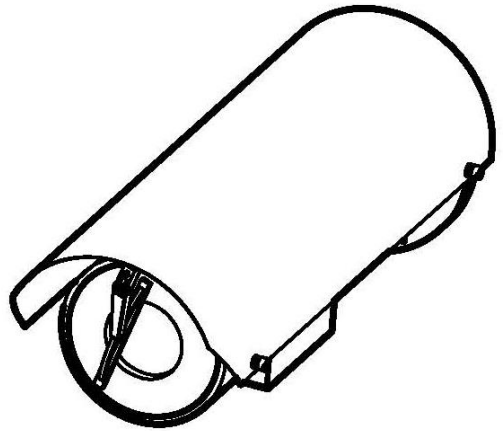

## SVEX-T300A EXPLOSIONPROOF CAMERA HOUSING



## SAFETY NOTES

Please carefully read the Manual Book before your operation

### **1. Installation**

- 1、 Please read manual carefully before installation and application, and obey the import notice.
- 2、 Ensure power off before the equipment is maintained and repaired.
- 3、 Do not open the equipment under serious lampblack, dust, high temperature, moisture condensation , otherwise video picture will be influenced.
- 4、 Please connect cable correctly, otherwise it will break down.
- 5、 Ensure protect flameproof cover when the equipment is maintained, avoid metal fragment or other object into the inner side of the equipment.
- 6、 Do not decompose and reconstruct the equipment.

### **2. Environmental protection**

The products contain spare parts which may pollute the environment, e.g. PCB, electric component, plastic goods, lubricating grease and so on. Please collect and control the pollution sources when the equipment is maintained and scrapped. Don't discard it. Please pass it to environmental department, or it will influence the environment.



## CONTENT

1. BRIEF .....	5
2. TECHNICAL DATA .....	5
2.1 Type code .....	5
2.2 Certificate .....	6
2.3 Mode .....	6
2.4 Electrical .....	6
2.5 Mechanical .....	6
2.6 Environmental .....	7
2.7 Dimension .....	7
2.8 Installation size .....	8
3. INSTALLATION .....	8
3.1 Installation of camera and lens .....	8
3.2 Cable treatment .....	9
3.3 Housing installation .....	10
3.4 Terminal block .....	11
3.5 Inner structure : SVEX-T 300A .....	12
3.6 Inner structure : SVEX-T300B .....	12
3.7 Install housing to electric Pan/Tilt .....	13
3.8 Install housing to fixed bracket .....	13
3.9 Installation caution .....	13
4. FLAMEPROOF STRUCTURE .....	14
5. TROUBLE SHOOTING .....	14
6. SHIPMENT AND STORAGE .....	14
7. INSTALLATION ACCESSORY .....	15
8. GUARANTEE .....	16
9. STATEMENT .....	16

## 1. BRIEF

**SVEX-T300A Ex-proof housing** is mature Ex-proof monitor equipment. It is approaching to advanced manufacture technology. Because of the demand of high quality control system, the quality and function of the products are in the lead of this field. SVEX-T300A has the character of small size, light weight, collocate nimble and so on.

**SVEX-T300A Ex-proof housing** is Strictly according to European Directive EC/94/9 and EN50014, Standards of GB3836.1-2000 GB3836.1—2000 Electrical apparatus for explosive atmosphere: General requirements, GB3836.2-2000 Electrical apparatus for explosive atmosphere: Flameproof 'd' and GB12476.1-2000 Electrical apparatus for explosive dust: Using enclosure and limiting surface temperature for protecting electrical apparatus Chapter 1: Technical requirements. The housing is made of stainless steel, Ip68

SVEX-T300 Ex-proof housing has 2 kinds. The one is the long type which can be installed zoom lens; another one is the short type which can be installed fixed lens camera or integrated camera.

## 2. TECHNICAL DATA

### 2.1 Type code

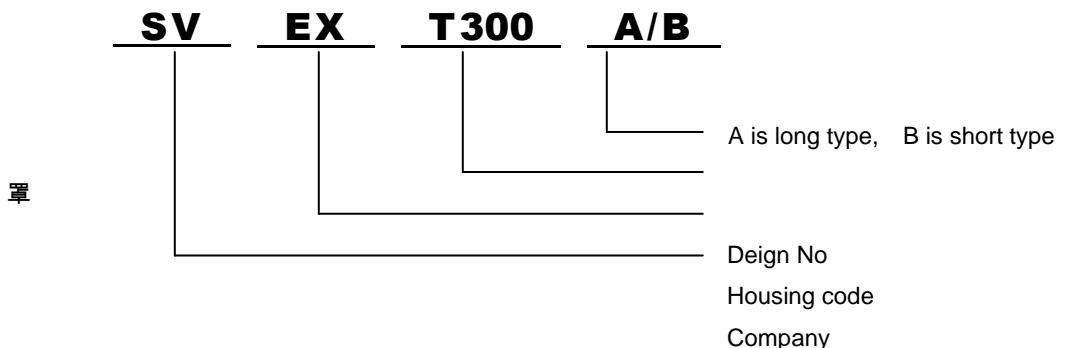

## 2.2 Certificate

Ex-marking	Exd IICT6/ DIP A20 TA, T6
License	XK06-123-00251
Certificate	CNEx07.1032X

## 2.3 Mode

SVEX-T300A	Ex-proof housing, long type
SVEX-T300B	Ex-proof housing, short type

## 2.4 Electrical

Input Voltage	220VAC or 24VAC 50/60Hz
Input Voltage Scope	±10%
Working Current	≤0.5A
Camera power	12VDC (outer equipment offers)
Auto-heat	Work while it is below -10°C±5°C
Power Consumption	30W
Electric Connection	2-core cable is used for power 4-core cable is used for lens control Video is used to output video signal

## 2.5 Mechanical

Material	stainless steel 304 or 316L
Protection	IP66
Dimension	
SVEX-T300A	540(L) x 190(H) x 186(W) mm
SVEX-T300B	431(L) x 190(H) x 186(W) mm
Inner diameter	
SVEX-T300A	260(L) x 90(H) x 70(W) mm
SVEX-T300B	140(L) x 90(H) x 70(W) mm
Window	Thickness 15mm
Window area	Φ66mm
Weight/Ship weight	

SVEX-T300A	14Kg / 16Kg
SVEX-T300B	11.5Kg / 13Kg
Outlet hole quantity	3
Outlet hole screw thread size	G-3/4"
Mount type	Electric Pan/Tilt, fixed Pan/Tilt, fixed bracket

## 2.6 Environmental

Air Pressure	86 ~ 106KPa
Environment Temperature	-25°C~+60°C
Relative Humidity	≤95%RH (+25°C)

## 2.7 Dimension

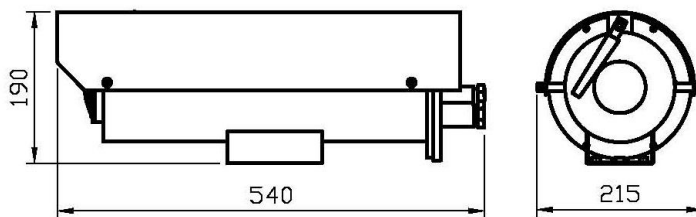

P1. SVEX-T300A ex-proof housing dimension

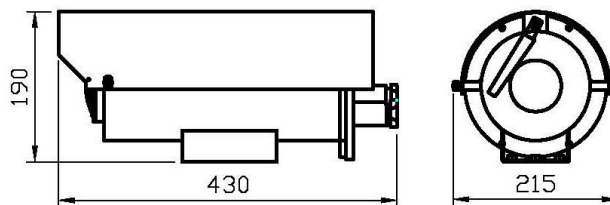

P2. SVEX-T300B ex-proof housing dimension

## 2.8 Installation size

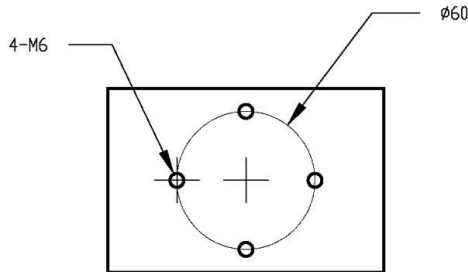

**P3. Bottom fixed hole of housing**

## 3. INSTALLATION

### 3.1 Installation of camera and lens

Read the manual book carefully before installation. Check weather lens and CCD connector are matched. 1/3 inch CCD camera can be installed to 1/3 or 1/2 inch lens. 1/2 inch CCD camera only can be installed to 1/2 inch camera. Otherwise it may appear dark corner.

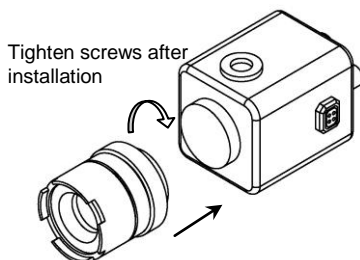

**P4. Lens installation**

After lens and camera installed, adjust back focal length of the camera. Observe the sharpness of the testing card in the monitor.

Install the adjusted camera to the drawer of the housing. Adjust the position, ensure the picture has no dark corner after installed barrel.

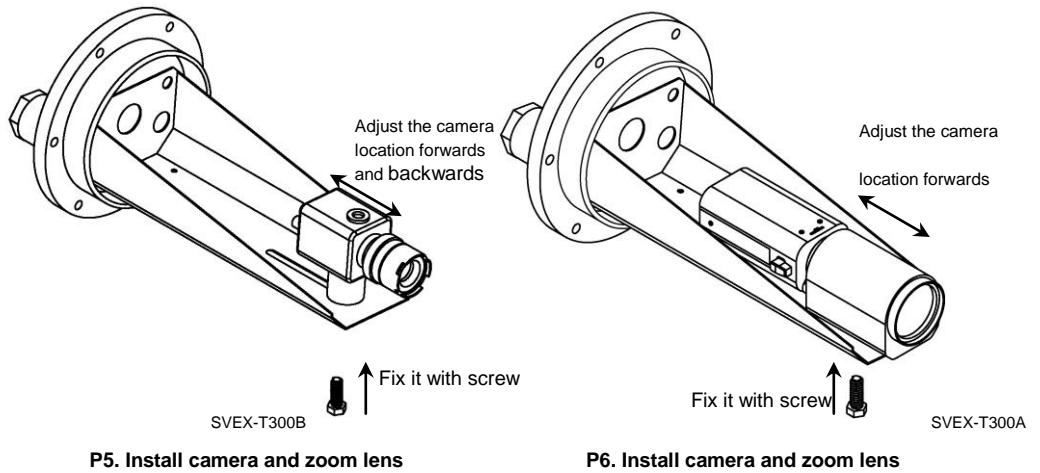

## 3.2 Cable treatment

### 3.2.1 Use Ex-proof Flexibility Tube

a. As picture 7, put on the Ex-proof flexibility part to cable, remove the Tighten Nut, keep the original gasket and rubber loop (or use the spare parts).

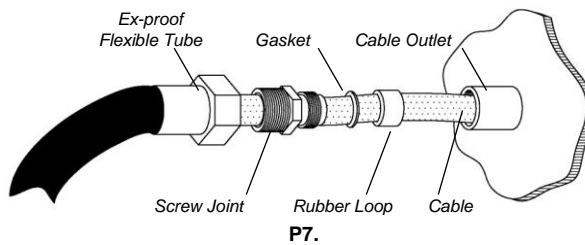

b. As Picture 8, firstly turn tight the screw connection head and then tight the Ex-proof Flexibility Tube.

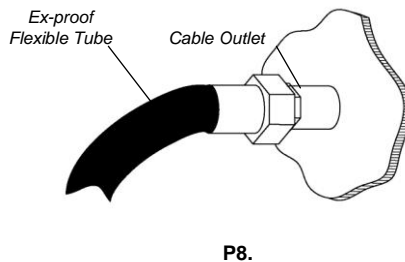

### 3.2.2 Use Armored Cable

a. As picture 9, remove proper length cable protection cover and cut off not used part.

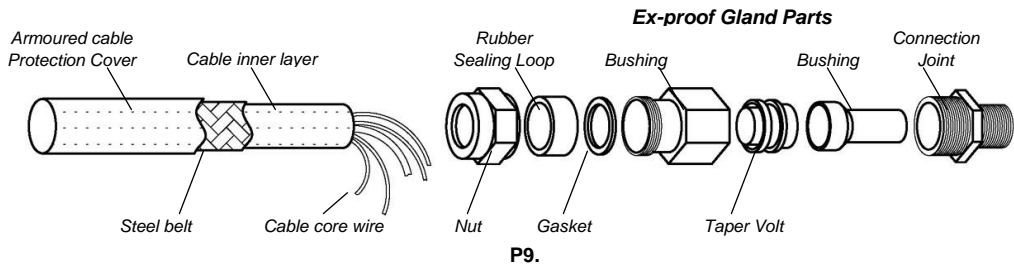

b. As Picture 6, install Ex-proof Gland to Armoured Cable, as the method please refer to Document for Installation of Ex-proof Gland.

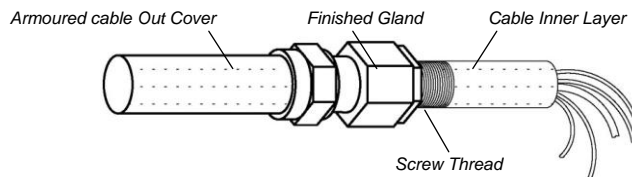

c. Armored cable with ex-proof Gland could connect with any ex-proof equipment directly

### 3.3 Housing installation

Because of the high level ex-proof, the flameproof joint of the housing is very strictness. Pay attention to the protection of the flameproof joint when installing. As picture 11, back of the post operculum and barrel is flameproof joint. No hurting or scratching when installing.

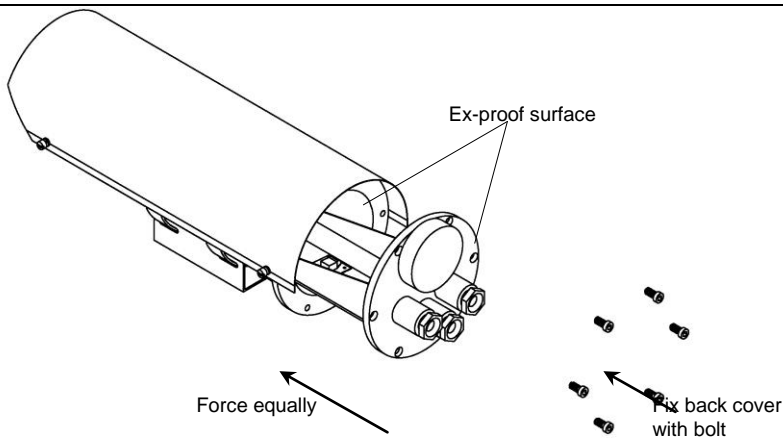

**P11. Install back part of ex-proof housing carefully**

Insulation spacer is used between drawer board and back cover plate. Pay attention to the insulation character in case it needs to be dismantled. The insulation resistance is more than 100 M $\Omega$  after installation. Center of the post operculum is connected circumscribed bolt. It should be installed when equipment installation.

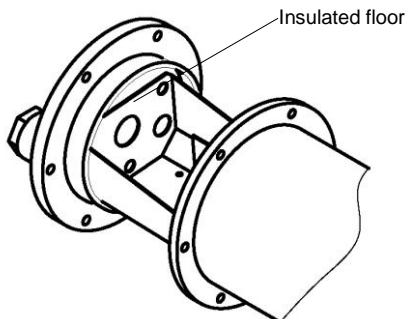

**P12. Pay attention to the insulating layer between post operculum and drawer**

### 3.4 Terminal block

As P13

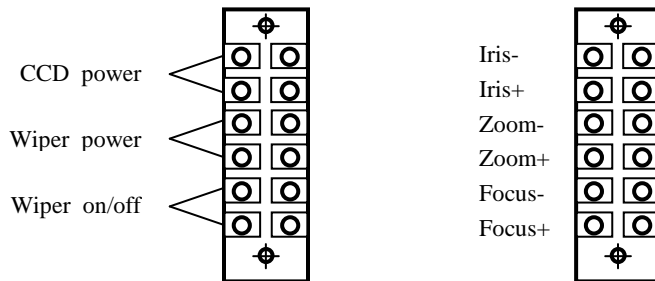

**P13. Terminal block of the barrel**

### 3.5 Inner structure SVEX-T300A

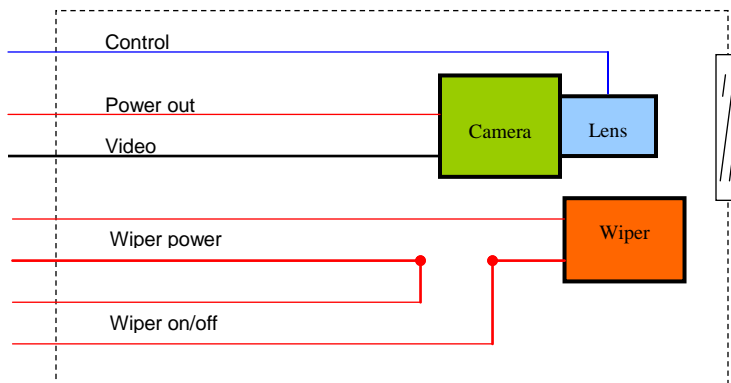

**P14. SVEX-T300A inner structure for camera and zoom lens**

### 3.6 Inner structure SVEX-T300B

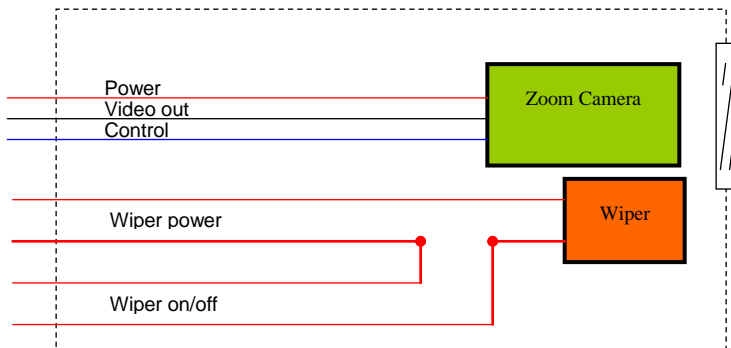

**P15. SVEX-T300B inner structure, integrated camera installation**

### 3.7 Install housing to electric Pan/Tilt

Follow the manual book of electrical pan/tilt.

### 3.8 Install housing to fixed bracket

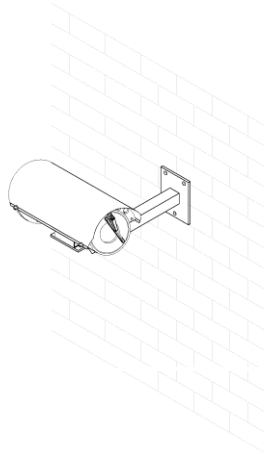

P16. SVEX-T300 bracket picture

### 3.9 Installation caution

- Please carefully check before installation
  - a. If there is ex-marking license
  - b. The ex-marking satisfy environment use
  - c. All ex-proof and flameproof parts are complete enough for structure
- Choose the correct cable; lead in cable diameter should match to the seal rubber ring. According to the seal rubber ring, choose the smallest outer diameter. Keep to tighten nuts and seal rubber ring is under the demand of ex-proof.
- The nameplate and warning sign “No opening when power on” shows in the clear area.
- Choose inner hole  $\Phi 8$  seal ring when installing connection. End face shows  $\geq \Phi 7.5$ .

Choose the outer diameter of the cable matched to the inner hole diameter of the seal ring.  
As picture 17.

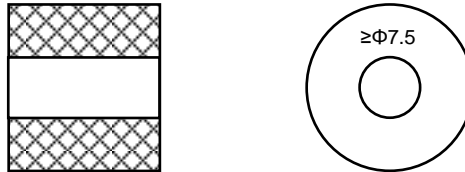

**P17. Seal ring picture**

#### 4. FLAMEPROOF STRUCTURE

- Completely consider the explosive air getting into ex-proof structure, which may lead to explosion because of some reason and to confirm and ensure camera explosion proof performance based on its structure gap, length and max temperature it will get to.
- Enclosure shall burden water pressure testing for 1.5Mpa for 10~12 seconds without leakage as pass, which is ordered in GB3836.2-2000.
- Camera surface temperature max shall not over 80°C while it is working
- Window glass adopts steel glass to burden Impact and Heat change testing.
- Window glass adopts steel glass to burden Impact and Heat change testing.

#### 5. TROUBLE SHOOTING

Problems	Reason	Method	Mark
No image	Power off	Check connection	Do it oneself
	Signal line off	Check connection	Do it oneself
	Camera is broken	Change a camera	Communicate with manufacturer
	Lens are broken	Change lens	Communicate with manufacturer

#### 6. SHIPMENT AND STORAGE

After package, without rain or snow fall directly to product, shipment could do by air or sea and store for one year under the environment of 0°C~+40, humidity >90%.

## 7. INSTALLATION ACCESSORY

8mm rubber seal ring will be installed in the camera outlet hole. 8mm blockage and press tighten nuts should be installed as well. One 10mm, one 12mm rubber seal ring and desiccant are offered. The housing offers 1/4"6mm、12mm screw when requested.

Other accessory: (They will be ordered in addition)

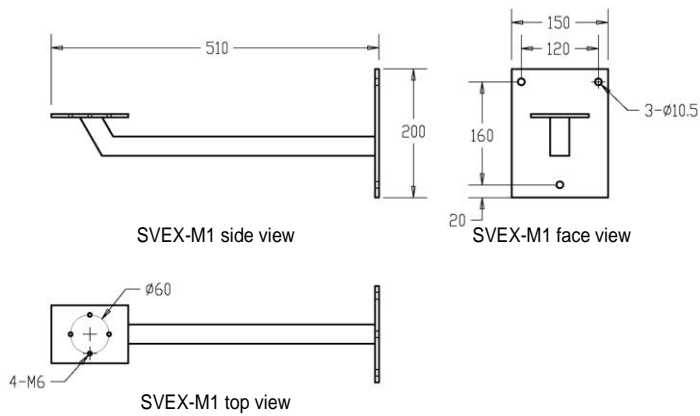

### P18. SVEX-M1 wall mounting bracket for SVEX-T300A

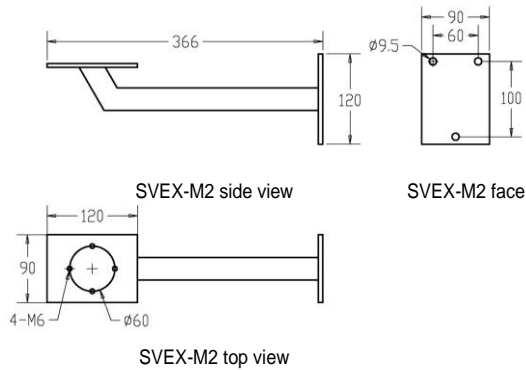

### P19. SVEX-M2 wall mounting bracket for SVEX-T300B

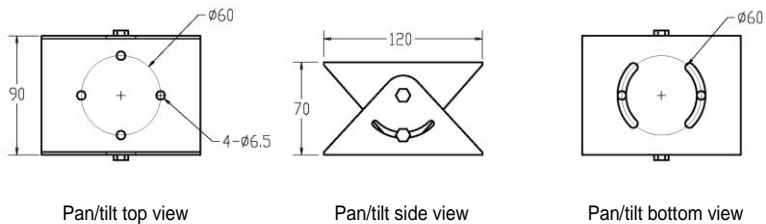

---

**P20. SVEX-F1 swivel (included in the SVEX-F1/2 bracket)****8. GUARANTEE**

For any camera produced by VEILUX, INC, we promise one year warranty.

During warranty, we supply free service except following situations:

- User does not operate as manual book requires
- User un-install the whole product by themselves
- Lightning or Act of God

If there are additional agreements between VEILUX, INC and buyer, then agreements shall be strictly done.

**9. STATEMENT**

- VEILUX, INC. owns the final design changing and final specification rights and no responsibility to inform user
- This manual book belongs to VEILUX, INC. rights, without permits or any book inform, any company or private copy of whole or part of the book shall be prohibited.



**3015 EAGLE DR. STE. 100**  
**GRAND PRAIRIE, TX. 75052**