

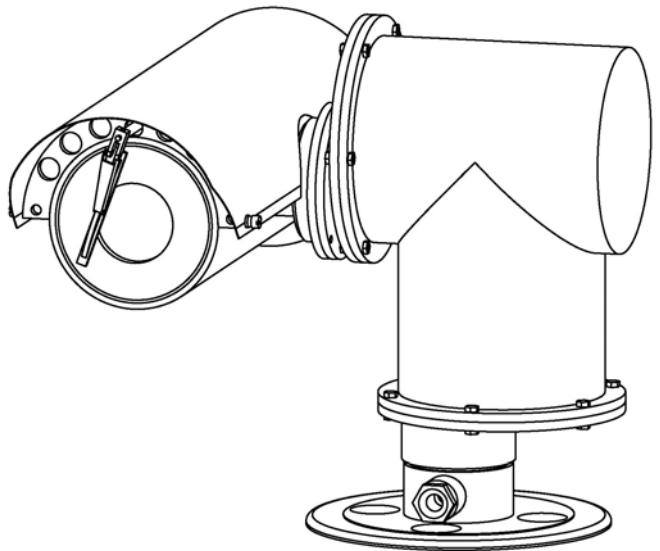

Ex marking ExdIICT6/EEExdIICT6

Certificate No CNEx05.0223X

Nemko 05ATEX1190



SVEX-W125 Explosion Proof Integrated Camera

Manual Book

Veilux Inc.



Safety Instruction

Please carefully read the Manual Book before your operation

1. Installation

- Please install under required environment
- Ensure stable and reliable mounting in case camera be damaged
- Ensure supply power same as nameplate marked before equipment being powered
- Do not open the pan/tilt and enclosure under humid atmosphere, otherwise video picture will be influenced because of enclosure good sealing, humidity could not go outside
- Please connect cable correctly

2. Maintenance

- Please shut off before maintenance and repair
- Pay attention to the flameproof joint while disassembly and assembly

Content

1. BRIEF	4
2. TECHNICAL DATA	4
2.1 Type Code	4
2.2 Certificate	5
2.3 Electrical	5
2.4 Camera	5
2.5 Mechanical	5
2.6 Environmental	5
2.7 Dimension	6
2.8 Installation Size	6
3. INSTALLATION	7
3.1 Caution	7
3.2 Pole Mount Installation	7
3.3 Wall Mount Installation	8
3.4 Cable Treatment	8
3.4.1 Use Ex-proof Flexibility Tube	8
3.4.2 Use Armored Cable	9
4. APPLICATION	10
4.1 System Connection	10
4.2 Cable Definition	12
5. FLAMEPROOF STRUCTURE	12
6. TROUBLE SHOOTING	13
7. SHIPMENT AND STORAGE	13
8. GUARANTEE	13
9. STATEMENT	14

1. BRIEF

This SVEX-W125 EX EXPLOSION PROOF Integrated CAMERA therefore as SVEX-W125 Camera new monitoring equipment adopts advanced production techniques and matured quality management system to make its quality, performance and appearance a leading position in explosion proof monitoring products. It can be used in flammable and explosive environment to realize monitoring purpose.

Strictly according to European Directive EC/94/9 and EN50014, Standards of GB3836.1-2000 GB3836.1—2000 Electrical apparatus for explosive atmosphere: General requirements, GB3836.2-2000 Electrical apparatus for explosive atmosphere: Flameproof 'd' and GB12476.1-2000 Electrical apparatus for explosive dust: Using enclosure and limiting surface temperature for protecting electrical apparatus Chapter 1: Technical requirements, this camera owns advantage of small volume, light weight and easy installation features and could be used in petroleum, chemical industry, jetty, port, mine, space, army and foodstuff area.

SVEX-W125 with speedy pan/tilt can response any host machine directives. The Camera body adopts integrated structure design, no cable between camera housing and pan/tilt, goes 350° turning horizontally and ±90° pitching. Camera with sunshield, wiper and desk base brackets are optional.

IMPORTANT NOTICE:

SVEX-W125 IS INTEGRATED WITH PAN/TILT AND CAMERA HOUSING. THERE IS NO BUILT-IN TELEMETRY/RECEIVER. THEREFORE, IT MUST WORK WITH ADDITIONAL TELEMETRY UNIT.

2. TECHNICAL DATA

2.1 Type Code

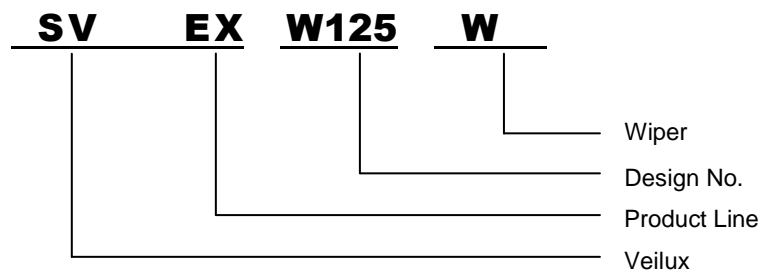

2.2 Certificate

Ex-marking	Exd ^o CT6 / EExd ^o CT6
ATEX Certificate	Nemko 05ATEX1190

2.3 Electrical

Input Voltage	220VAC/24VAC, 50/60Hz
Input Voltage Scope	±10%
Working Current	< 1A
Power Consumption	85 W
Electric Connection	
Pan/Tilt	7-core wire for pan/tilt driving and auto heating
Camera housing	coaxial cable 8-core cable for connecting camera power, lens control and auto heating
Auto-heating (optional)	works under -10 ^o

2.4 Camera

SONY FCB-EX series and Hitachi VK-S858EN are recommended.

2.5 Mechanical

Material	Stainless Steel 1Cr18Ni9Ti or 316L
Protection	IP67
Pan	0~350°
Tilt	±90°±2°
Pan/Tilt speed	3.8°/S
Unit weight	49Kg
Shipment weight	53Kg
Mounting	Bracket, base or pole mounting

2.6 Environmental

Air Pressure	86 ^o ±106KPa
Environment Temperature	-40 ^o ~+60 ^o (with auto-heat)

Relative Humidity ≤95%RH (+25℃)

2.7 Dimension

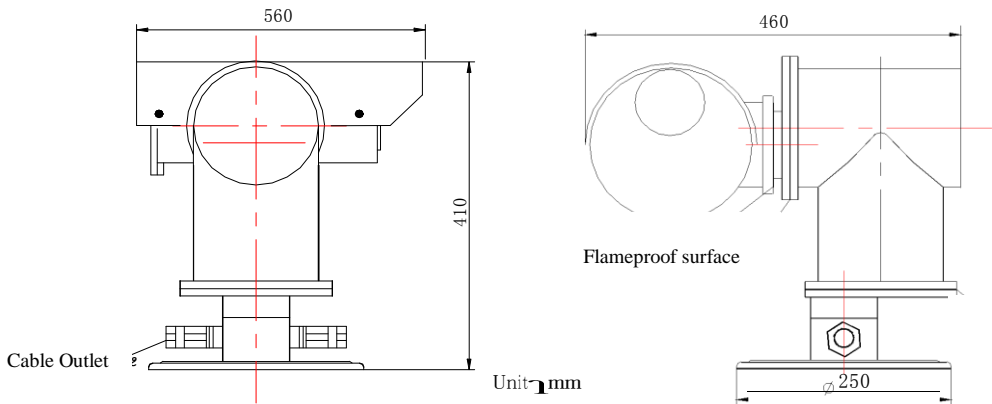

P1. SVEX-W125 Dimensions

2.8 Installation Size

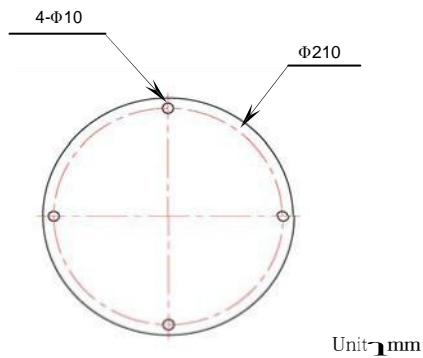

P2. SVEX-W125 mounting size

3. INSTALLATION

3.1 Caution

Please carefully check before installation

- a. If there is ex-marking license
- b. The ex-marking satisfy environment use
- c. All ex-proof and flameproof parts are complete enough for structure
- d. Inside and outside are ready
- e. Pay attention to the “forward” mark on the camera.

3.2 Pole Mount Installation

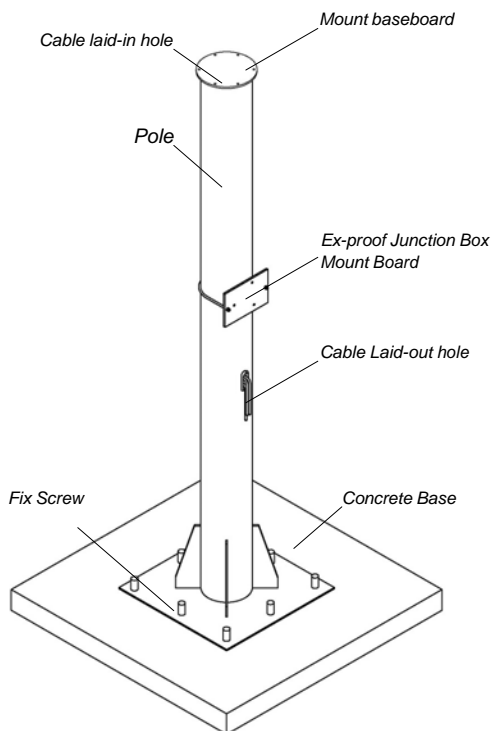

P 3. Make the Concrete Base and Install Pole

Make concrete base before install pole and previously lay screws and some holes for cable out under the base. Attention: Pole's type shall changes according to monitoring scope, wind speed and height. So please consult the supplier while designing the pole.

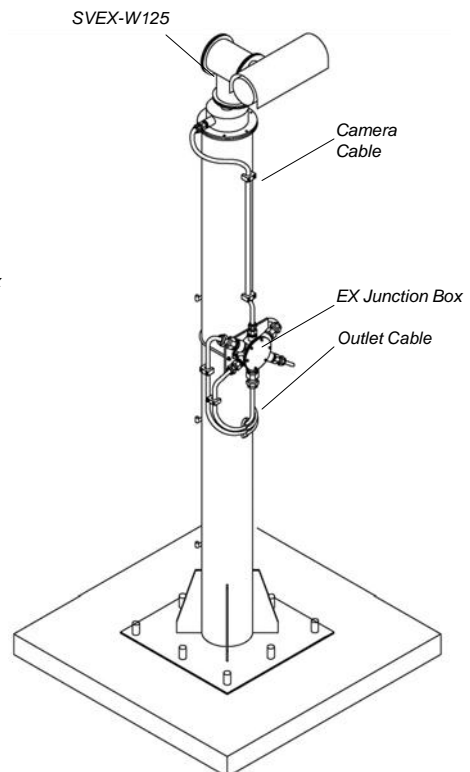

P4. Mount Camera and Connect Cable

As show in Picture 2 and 4, make the camera bottom cable through Cable Laid-in hole. The Junction Box normally locates at a easy installation and maintenance level with screw fixed, and must be with ex-proof tube for protection or with armored cable.

3.3 Wall Mount Installation

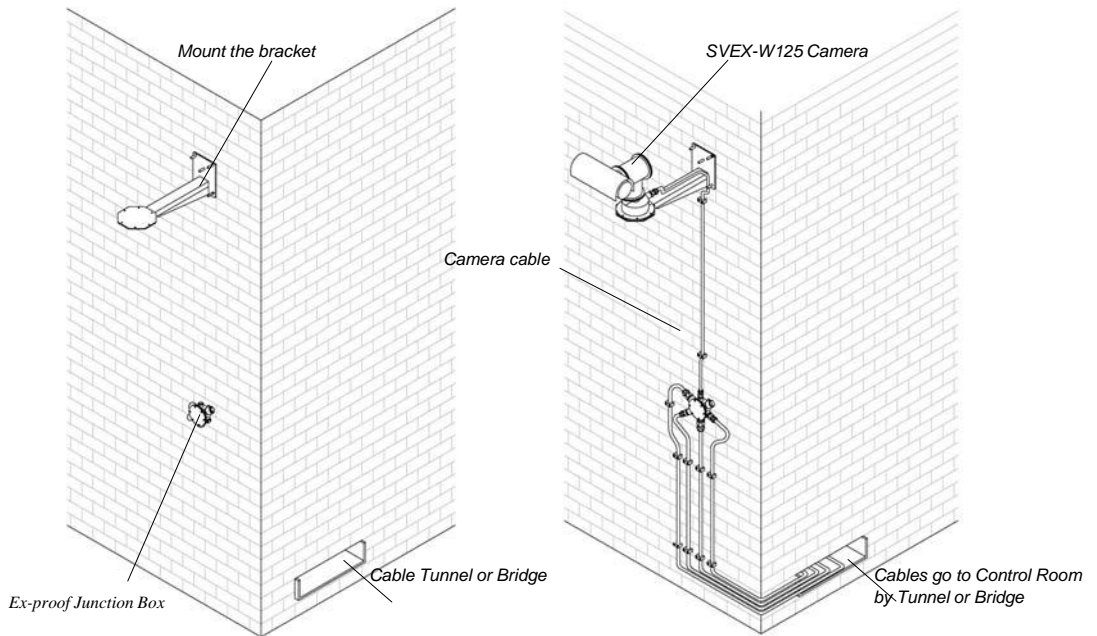

P5. Mount Bracket and Junction Box

Make a mount hole at proper level and fix the bracket with screw. Junction Box shall be at easy work level and cable goes through tunnel or bridge to nearby Junction Box.

P6. Mount Camera and Connect Cables

Refer to Picture 2 to mount camera bottom, and make the camera cable go through cable hole on the bracket until reaching Junction Box. With Ex-proof Flexibility Tube for protection or armored cable

3.4 Cable Treatment

3.4.1 Use Ex-proof Flexibility Tube

- a. As P7, put on the Ex-proof flexibility part to cable, remove the Tighten Nut, keep the original gasket and rubber loop (or use the spare parts).

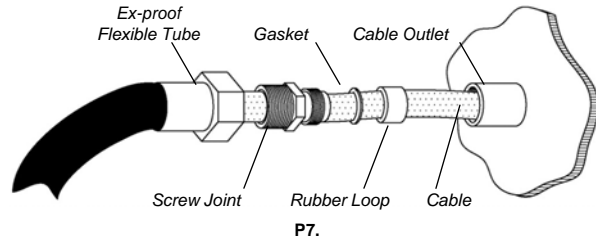

b. As P8, firstly turn tight the screw connection head and then tight the Ex-proof Flexibility Tube.

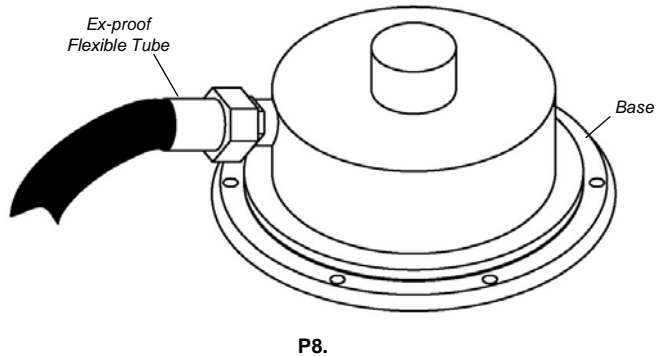

3.4.2 Use Armored Cable

a. As Picture 9, remove proper length cable protection cover and cut off not used part.

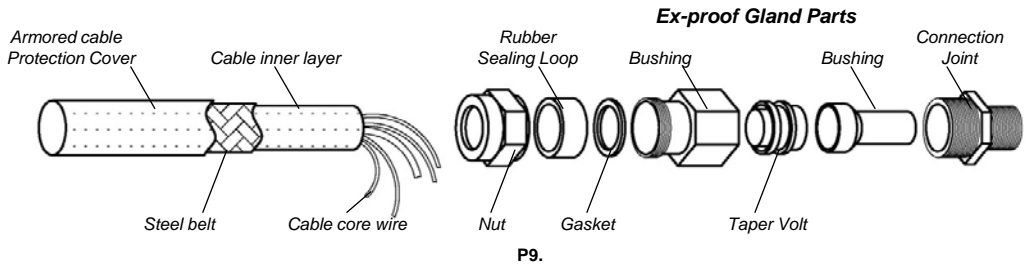

b. As Picture 10, install Ex-proof Gland to Armored Cable, as the method please refer to Document for Installation of Ex-proof Gland.

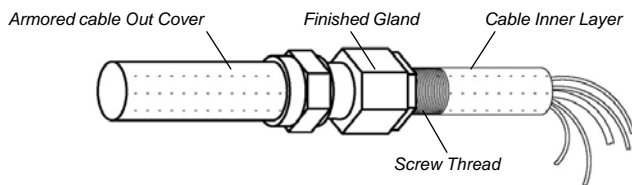

c. Armored cable with ex-proof Gland could connect with any ex-proof equipment directly

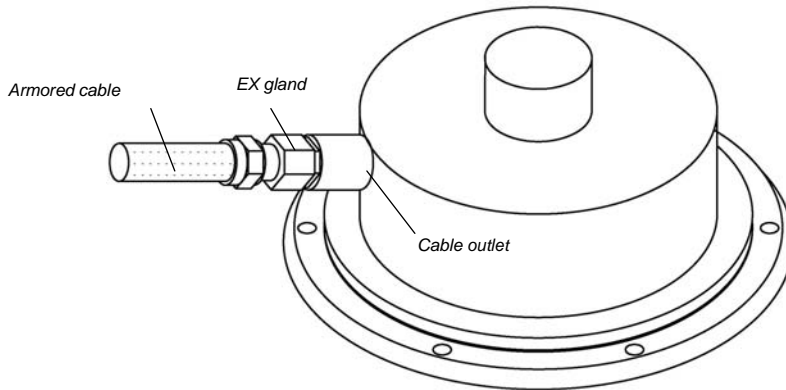

P11.

4. APPLICATION

4.1 System Connection

Since the wall of the flameproof enclosure is thick and the seal is well, it is not favorable to heat dissipation. So, do not continuous operation for a long term. 20 minutes' rest is required after 40 minutes' work.

To accommodate most camera and lens combinations, the CCD and lens in this camera set are absent as it delivery, they will be installed by the manufacturer after selected by user in the order. When installation, it should be following the instruction strictly, otherwise, it may cause the electrical fault or damage.

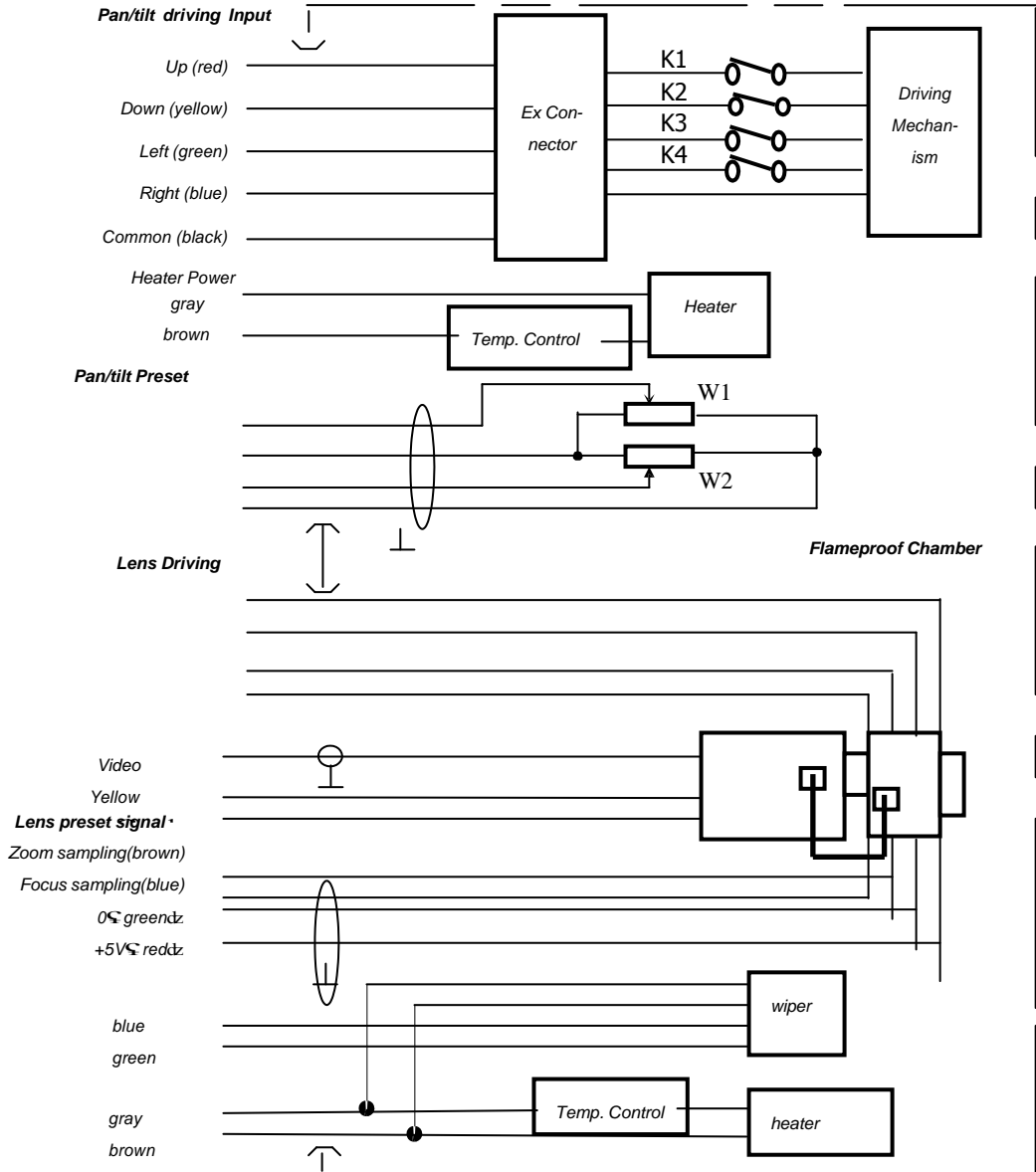

P12. Pan/Tilt Wire Connection

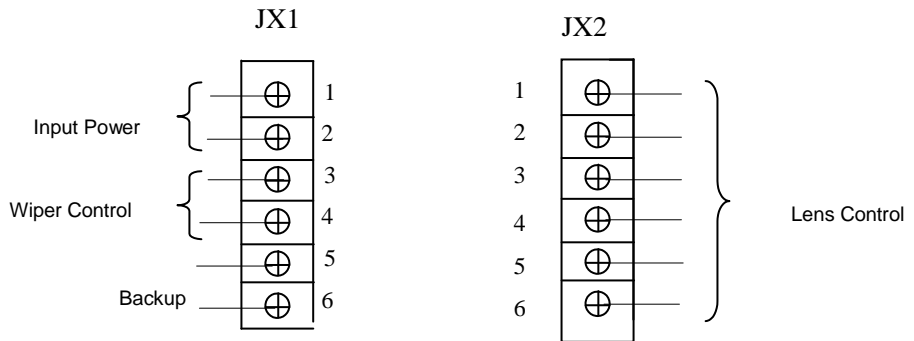

P13. Camera Connection

4.2 Cable Definition

Item	Composite Cable									
Item	11-Core Cable									
Function	Pan/Tilt Direction Control					Heater Power 220V	Preset (Shielded Cable)			
	Up	Down	Left	Right	Common		Red	Green	Brown	Blue
Color	Red	Yellow	Green	Blue	Black	Brown/Gray	Vcc	Ch0	Ch1	Vss
Item	14-Core Composite Cable									
Function	CCD Power Thick Wire			Lens Control Thin Wire				Wiper Control Thick Wire		
	+12V	GND		Common	Focus	Zoom	Iris	Power		Switch
Color	Red	Yellow		Brown	Green	Blue	Red	Brown	Gray	Green Blue
Function	4-Core Composite Cable Lens Preset Signal Shielded cable									
Color	Zoom Sampling			Focus Sampling		0		+5V		
	Brown			Blue		Green		Red		

5. FLAMEPROOF STRUCTURE

- Completely consider the explosive air getting into ex-proof structure, which may lead to explosion because of some reason and to confirm and ensure camera explosion proof performance based on its structure gap, length and max temperature it will get to.
- Enclosure shall burden water pressure testing for 1.5Mpa for 10~12 seconds without leakage as pass, which is ordered in GB3836.2-2000.

- Camera surface temperature max shall not over 80℃ while it is working.
- Window glass adopts steel glass to burden Impact and Heat change testing.
- Enclosure protection to IP67.
- Cable for Camera uses inlaid device to tighten its screw and nut and make cable tight and no move.

6. TROUBLE SHOOTING

Problems	Reason	Method
No image	Power off	Make sure the power is ok
	Video cable not good connection	Check the Video Cable
Sometime no image	Video cable not good connection	Check the Video Cable
Control error	Not good connection of Signal cable	Check Signal Cable is correct connection
	Too long communication distance make signal loose	Add repeaters to make communication distance longer
	Signal reflect	Short connect the farthest camera decoder board JMP1 and add 120Ω resistance to remove reflect
	Not correct Address	To re-set refer to Manual book
	Not correct Protocol	
Not correct Baud rate		

7. SHIPMENT AND STORAGE

After package, without rain or snow fall directly to product, shipment could do by air or sea and store for one year under the environment of 0℃ ~+40℃ , humidity >90%.

8. GUARANTEE

For any camera produced by VEILUX, we promise half-year to change and one year to repair.

During Guarantee period, we supply free service except following situations:

- User does not operate as manual book requires
- User un-install the whole product by themselves
- Lightning or Act of God

If there are additional agreements between VEILUX and buyer, then agreements shall be strictly done

9. STATEMENT

- VEILUX owns the final design changing and final specification rights and no responsibility to inform user
- This manual book belongs to VEILUX rights, without permits or any book inform, any company or private copy of whole or part of the book shall be prohibited.



802 GREENVIEW DR STE 200

GRAND PRAIRIE, TX. 75050

Website: www.veilux.net

E-mail: Sales@veilux.net

Phone # 1-800-510-6528