

SVEX-XX1-Z

Explosion-proof Monitor



VEILUX
The Art of Surveillance



Specifications:

CERTIFICATE	
Certificate Mark	Ex d IIB T6 Gb / Ex tD A21 IP68 T80 °C
MECHANICAL	
Housing	Carbon steel, Stainless steel 304 or 316L
IP	IP68
Cable Thread Hole	4pcs G3/4 or NPT3/4 or M25*1.5
ELECTRICAL	
Voltage	AC100-240V
Power	50W
Surge Protect	Optional, TVS6000V surge protect
Video Input	1Vp-p Positive polarity, full TV signal 75Ω imbalance
AMBIENT	
Ambient Temperature	-40 °C to +60 °C
Air Pressure	80Kpa to 110Kpa
Relative Humidity	≤95% (no condensation)
Video System	PAL/ NTSC
Panel Life	30,000 hours
View Degree (H/V)	170°/160°
Connector Port	HDMI or VGA, or BNC, S-VHS, RGB, CVBS
Cable	Integrated cable - 2m long

FUNCTION						
Screen LED	15inch	17inch	19inch	21.5inch	22inch	24inch
Resolution	1024x768	1280x1024	1280x1024	1920x1080	1920x1080	1920x1080
Aspect Ratio	4:3	4:3	16:9	16:9	16:9	16:9
Size (mm)	445x223x408	475x230x429	545x199x4656	645x230x446	645x230x459	707x230x461
Weight	28kg	38kg	45kg	55kg	55kg	65kg
Brightness	220 nits	250cd/m2				
Contrast	700:1	1000:1				
Response	8/4 (Tr/Td) ms	5ms(G To G)				

SVEX-XX1-Z

Explosion-proof Monitor



VEILUX
The Art of Surveillance

Dimensions:

15" inch Monitor

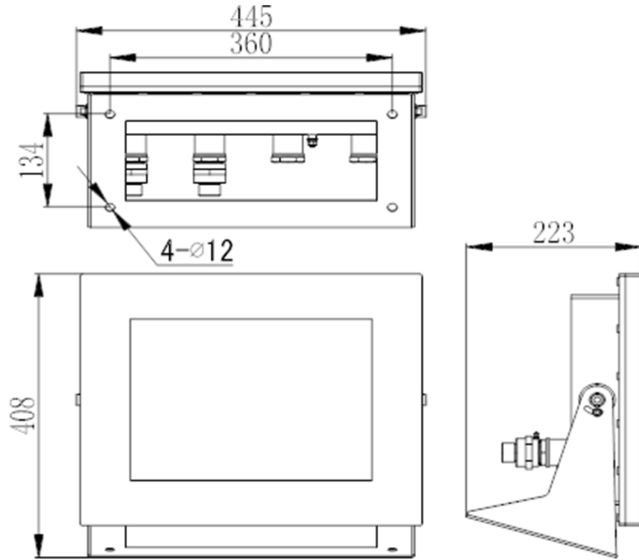

17" inch Monitor

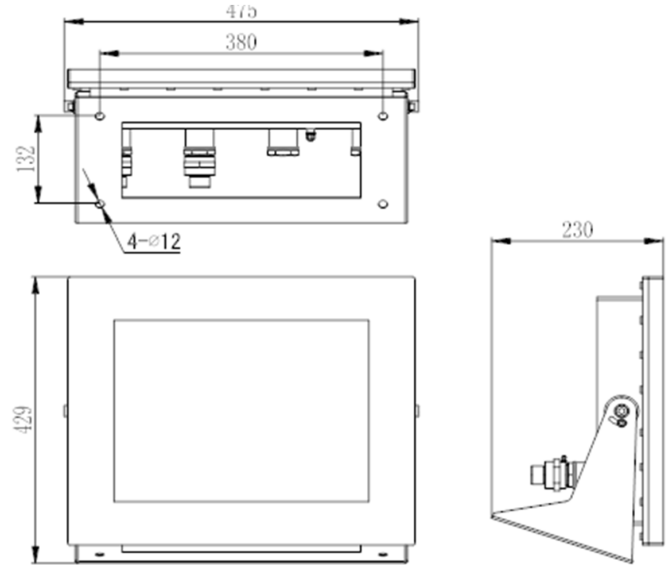

19" inch Monitor

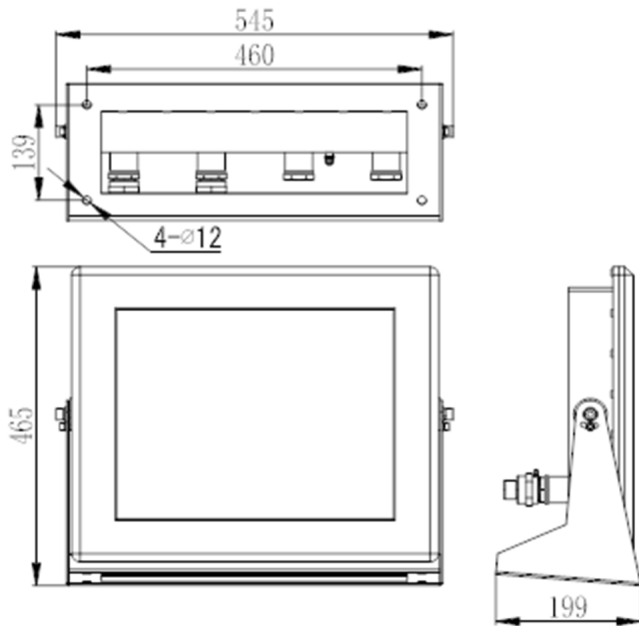

21.5" inch Monitor

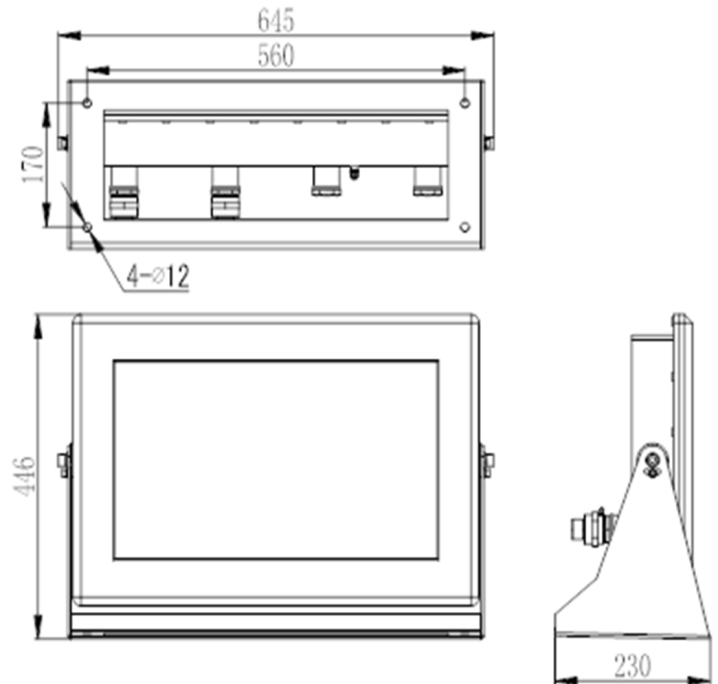

SVEX-XX1-Z

Explosion-proof Monitor



VEILUX
The Art of Surveillance

Dimensions:

22" inch Monitor

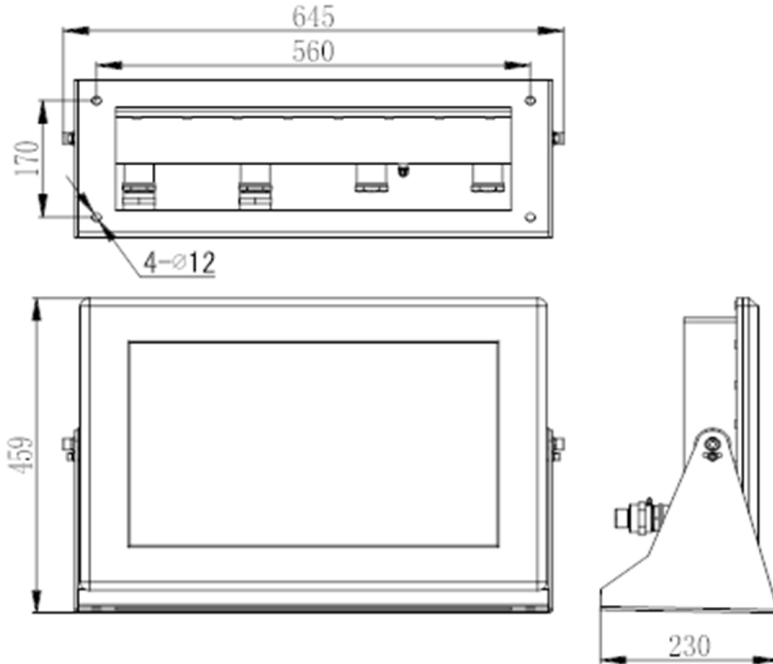

24" inch Monitor

